

Late Report Ordinary Meeting Of Council



Wollondilly Shire Council

Late Report – Monday 16 May 2016

TENDER 2016/06 PICTON SPORTSGROUND PEDESTRIAN BRIDGE DESIGN AND
CONSTRUCT

62-64 Menangle Street Picton NSW 2571
PO Box 21 Picton NSW 2571
Phone: 02 4677 1100 Fax: 02 4677 2339
Email: council@wollondilly.nsw.gov.au
Web: www.wollondilly.nsw.gov.au



Wollondilly
Shire Council

Late Report to the Ordinary Meeting of Council held on Monday, 18 April 2016

IN3 – Tender 2016/06 Picton Sportsground Pedestrian Bridge Design and Construct

LATE REPORT

IN3 Tender 2016/06 Picton Sportsground Pedestrian Bridge Design and Construct

203

TRIM 8966

EXECUTIVE SUMMARY

- The purpose of this report is to recommend acceptance of a tender for the Picton Sportsground Pedestrian Link Bridge Design and Construct Contract in accordance with the Local Government Act 1993 and the Local Government (General) Regulation 2005.
- It is recommended;
 1. That in accordance with the Local Government (General) Regulation 2005, Clause 178 (1) (a), Council accept Option 2 of the tender from Fleetwood Urban Pty Ltd ABN 41 000 789 748 for the Picton Sportsground Pedestrian Link Bridge Design and Construct Contract for the tendered sum of \$425,221 (excluding GST) in response to Tender 2016/06.
 2. That Council delegate to the General Manager (or their delegate) the authority to finalise and execute the Contract and any other documentation required to give effect to the resolution, including those requiring the Common Seal of Council.
 3. That no contract be formed between the parties until the Execution of the Formal Instrument of Agreement by both parties.
 4. That the shortfall in budget allocation be sourced from the Sportsground Restricted Cash Account in the 2016/17 Capital Budget.

REPORT

BACKGROUND

At its April 2015 Council meeting, Council resolved to proceed with a Pedestrian Bridge located near the bend of the shared pathway behind Magnolia Drive to the Sportsground normally accessed off Fairley's Road. A number of other resolutions were made by Council at the April 2015 meeting to address some of the concerns expressed by the community during the consultation period. These included:

- That Council formalise the existing overflow parking at Picton Sportsground in conjunction with the Picton Sportsground Pedestrian Bridge construction
- That the parking situation in nearby residential areas be monitored following construction of the Picton Sportsground Pedestrian Bridge
- That any future upgrades to Picton Sportsground make provisions for adequate parking for sportsground users

IN3 – Tender 2016/06 Picton Sportsground Pedestrian Bridge Design and Construct

Subject to adoption of the recommendations, It is anticipated that work will start toward the end 2015/16 FY and be completed in the 2016/17 FY.

TENDERS

Open tenders were called in accordance with the Local Government Act 1993 (NSW) and the Local Government (General) Regulation 2005 (NSW). The details of the calling, closing and opening of tenders are:

- Tenders were called on the 22nd March 2016
- Tenders were advertised in the Sydney Morning Herald, via Tenderlink, Bush Telegraph and on Council's Website
- Non-Compulsory Pre Tender Briefing Sessions was held on-site on the 4th and 13th April 2016
- Tenders Closed on the 19th April 2016

A total of 15 submissions were received from 10 different parties as follows:

- Brefni Excavation & Earthmoving Pty Ltd (ABN 73 082 718 983)
- Bridgeworks Aust Pty Ltd (ABN 73 126 101 228)
- Brodyn Pty Ltd T/A TCQ Construction (ABN 82 001 998 830)
- Fleetwood Urban Pty Ltd – option 1 (ABN 40 000 789 748)
- Fleetwood Urban Pty Ltd – option 2 (ABN 40 000 789 748)
- Foley & Bear Pty Ltd t/a J&R Industries (ABN 42 105 081 669)
- Icon Metal Fabrications Pty Ltd (ABN 60 075 222 294)
- J C Butko Engineering Pty Ltd (ABN 76 161 249 663)
- Moodie Outdoor Products Pty Ltd (ABN not provided)
- Steelworks Engineering Pty Ltd - Option 1 (ABN 64 133 155 558)
- Steelworks Engineering Pty Ltd - Option 2 (ABN 64 133 155 558)
- Steelworks Engineering Pty Ltd - Option 3 (ABN 64 133 155 558)
- Timber Restoration Systems Pty Ltd – Option 1 (ABN 45 145 174 269)
- Timber Restoration Systems Pty Ltd – Option 2 (ABN 45 145 174 269)
- Timber Restoration Systems Pty Ltd – Option 3 (ABN 45 145 174 269)

Tenders were initially assessed by the Tender Evaluation Panel against the following Compliance Criteria:

Sub Category	Complying Y/N
Adequately completed all Forms	Y/N
Adequately provided all requested information	Y/N
Have included to provide suitable resources	Y/N
Reasonable acceptance of Conditions of Contract	Y/N
Attended Pre-Tender Meeting	Optional

Late Report to the Ordinary Meeting of Council held on Monday, 18 April 2016

IN3 – Tender 2016/06 Picton Sportsground Pedestrian Bridge Design and Construct

On this basis the following two tenders were considered non-complying and not further considered by the Evaluation Panel:

- Moodie Outdoor Products Pty Ltd
- Timber Restoration Systems Pty Ltd – Option 3

The remaining tenders were scored individually by the Evaluation Panel members and aggregated into a single score for each Tender with the following Criteria:

Category	Sub Category	Weighting %
1. Design 30%	1.1 Compatibility with Brief and Aesthetics	15
	1.2 Demonstrated Capacity (Design)	15
2. Construction 35%	2.1 WH & S systems/procedures	5
	2.2 Quality Assurance systems	5
	2.3 Demonstrated Capacity (Construction)	15
	2.4 Construction Schedule	5
	2.5 Environmental Management	5
3. Cost 20%	3.1 Tender sum incl. estimated value of exclusions and variations	20
4. Other 15%	4.1 Effective Communications And Working In A Partnership Approach	5
	4.2 Value adding to Design	5
	4.3 Value adding to Construction	5
	Total	100

Fleetwood Urban Pty Ltd provided two tenders (Options 1 and 2) that were ranked 2nd and 1st respectively at the end of the scoring process. Tender Option 2 was the preferred tender as it offered better flood compatibility and a design more aligned to the intended use of the location i.e. access to a regional sporting facility.

On this basis, the Tender Assessment Panel unanimously agreed to recommended acceptance of Option 2 of the tender from Fleetwood Urban Pty Ltd ABN 41 000 789 748 for the Picton Sportsground Pedestrian Link Bridge Design and Construct Contract in response to Tender 2016/06. The details of the assessment are contained within a confidential attachment to this report.

CONSULTATION

The Tender Evaluation Panel for Tender 2016-6 included representatives from Infrastructure Planning and Works Sections.

Late Report to the Ordinary Meeting of Council held on Monday, 18 April 2016

IN3 – Tender 2016/06 Picton Sportsground Pedestrian Bridge Design and Construct

Council consulted the community in the early stages of this project and this resulted in a resolution to formalise the existing overflow parking at Picton Sportsground in conjunction with the Picton Sportsground Pedestrian Bridge construction. A budget allocation has been included in the project funding in order to achieve this outcome.

It should also be noted that roadwork will be carried out on Fairleys Road as part of the 2016/17 Pavement Reconstruction Program that will assist with on street parking to further increase capacity.

FINANCIAL IMPLICATIONS

The budget that was been allocated in the 2015/16 Operational Plan for the project is \$397,000 and expenditure estimated to the end of 2015/16 is estimated at \$50,000 which includes works to date (including geotechnical investigations and tender document preparation).

The March 2016 Quarterly Budget Review being presented to the May Council meeting is recommending that \$347,000 of the project budget be reallocated into the 2016/17 budget as this is when the bulk of the works will be completed.

The tendered sum for the works under Contract is \$425,221. Works completed to date totals \$50,000 and an allowance for other works at the sportsground, outside the contracted engagement, is estimated at up to \$75,000 and includes commencement of pathway linkages and the provision of overflow parking.

As such the total expected expenditure for this project and associated works is expected to total approximately \$550,000. The estimated shortfall for the project compared to current allocations is \$153,000.

It is recommended that an additional budget allocation of \$153,000 be allocated from Council's Sportsground Restricted Cash Account in the 2016/17 Capital Budget.

ATTACHMENTS

1. Attachment 1 – concept drawings of the recommended submission
2. Confidential Attachment 2 - Tender Report - Tender for the Design and Construct of the Picton Sportsground Pedestrian Bridge - Request for Tender Number: 2016-6

RECOMMENDATION

1. That in accordance with the Local Government (General) Regulation 2005, Clause 178 (1) (a), Council accept Option 2 of the tender from Fleetwood Urban Pty Ltd ABN 41 000 789 748 for the Picton Sportsground Pedestrian Link Bridge Design and Construct Contract for the tendered sum of \$425,221 (excluding GST) in response to Tender 2016/06.

Late Report to the Ordinary Meeting of Council held on Monday, 18 April 2016

IN3 – Tender 2016/06 Picton Sportsground Pedestrian Bridge Design and Construct

2. That Council authorise the General Manager (or delegate) the authority to finalise and execute the Contract and any other documentation required to give effect to the resolution, including those requiring the Common Seal of Council.
3. That no contract be formed between the parties, until the Execution of the Formal Instrument of Agreement by both parties.
4. That an additional budget allocation of \$153,000 be allocated from Council's Sportsground Restricted Cash Account in the 2016/17 Capital Budget.

Late Report to the Ordinary Meeting of Council held on Monday, 18 April 2016



IN3 – Tender 2016/06 Picton Sportsground Pedestrian Bridge Design and Construct

ATTACHMENT 1 – 8966 – 16 MAY 2016

 <p>Fleetwood Fleetwood Urban Pty Ltd www.fleetwoodurban.com.au Ph: 1300 959 100</p> <p><i>Inspirational Communities</i></p>	<p>© 2015 Fleetwood Urban Pty Ltd. This part of the report is the intellectual property of Fleetwood Urban Pty Ltd. It is not to be reproduced, stored in a retrieval system, or transmitted in any form or by any means, electronic, mechanical, photocopying, recording, or by any information storage and retrieval system, without the prior written permission of Fleetwood Urban Pty Ltd. All rights in this report are reserved.</p>	<p>Confidential Property. It is to be reviewed, used, or disclosed only for the purposes stated in the conditions. It is not to be copied, reproduced, stored in a retrieval system, or transmitted in any form or by any means, electronic, mechanical, photocopying, recording, or by any information storage and retrieval system, without the prior written permission of Fleetwood Urban Pty Ltd. All rights in this report are reserved.</p>	<p>Confidential Property. It is to be reviewed, used, or disclosed only for the purposes stated in the conditions. It is not to be copied, reproduced, stored in a retrieval system, or transmitted in any form or by any means, electronic, mechanical, photocopying, recording, or by any information storage and retrieval system, without the prior written permission of Fleetwood Urban Pty Ltd. All rights in this report are reserved.</p>	<p>DESIGNED BY DS</p> <p>SCALE 1:10/04/2016</p>	<p>CLIENT WOLLONDILLY SHIRE COUNCIL</p>	<p>ARCHITECT FLEETWOOD URBAN Fleetwood</p>	<p>PRODUCT RACECOURSE CREEK SPORTSGROUND, PICTON</p>	<p>PRODUCT STIRLING™ BRIDGE</p>	<p>3D PRODUCT DRAWING</p>	<p>9157 01</p>
--	---	--	--	---	---	---	--	-------------------------------------	---------------------------	-----------------------

IN3 – Tender 2016/06 Picton Sportsground Pedestrian Bridge Design and Construct

ATTACHMENT 1 – 8966 – 16 MAY 2016

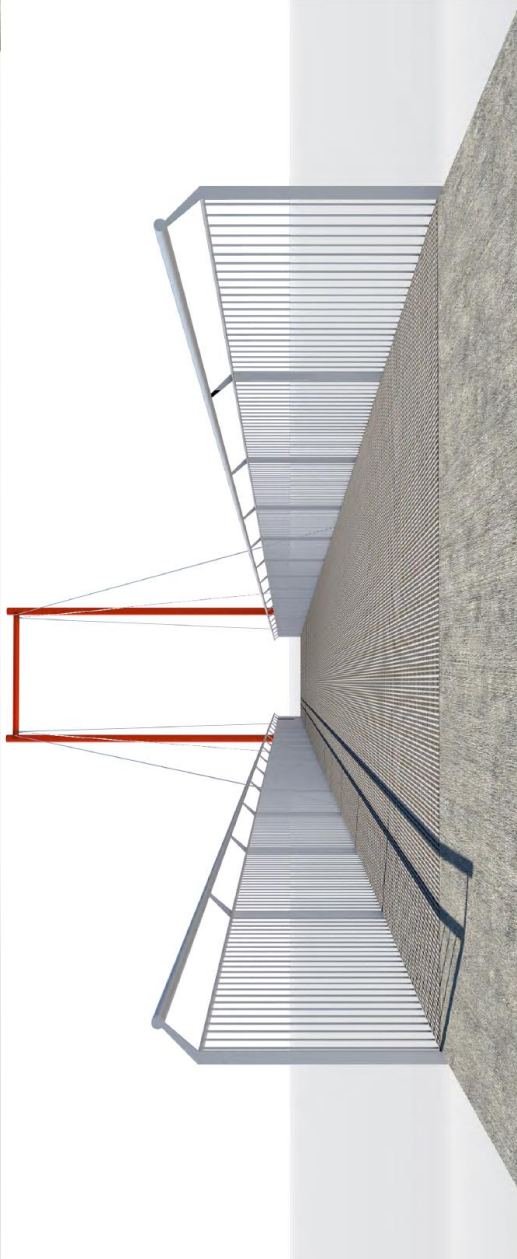
 <p>Fleetwood Fleetwood Urban Pty Ltd www.fleetwoodurban.com.au Ph: 1300 989 100</p> <p><i>Inspirational Communities</i></p>	<p><small>© 2015 Fleetwood Urban Pty Ltd. No part of this drawing may be copied, reproduced, scanned, or otherwise transmitted in any form or by any means, electronic or mechanical, including photocopying, recording, or by any information storage and retrieval system, without the prior written permission of Fleetwood Urban Pty Ltd.</small></p> <p><small>Conditions of Sale: Issued to you subject to the following conditions: 1. This drawing is for your information only and does not constitute an offer or any other financial product or service. 2. This drawing is not to be used for any other purpose without the prior written permission of Fleetwood Urban Pty Ltd.</small></p> <p><small>Geographical representation of products shown for information purposes only. Product shown is not intended to be used for any other purpose and may not reflect actual conditions.</small></p>	<p>DRAWN BY DS ISSUE 19/04/2016</p>	<p>CLIENT WOLLONDILLY SHIRE COUNCIL</p>	<p>ARCHITECT FLEETWOOD URBAN </p>	<p>PROJECT RACECOURSE CREEK SPORTSGROUND, PICTON</p>	<p>PRODUCT STIRLING™ BRIDGE</p>	<p>3D PRODUCT DRAWING</p>	<p>9157 02</p>
								

IN3 – Tender 2016/06 Picton Sportsground Pedestrian Bridge Design and Construct

ATTACHMENT 1 – 8966 – 16 MAY 2016



Fleetwood
Fleetwood Urban Pty Ltd
www.fleetwoodurban.com.au
Ph. 1300 889 100

Inspirational Communities

© 2015 Fleetwood Urban Pty Ltd. No part of this sheet may be copied, reproduced, stored in a retrieval system, or transmitted in any form or by any means, electronic, mechanical, photocopying, recording, or by any information storage and retrieval system, without the prior written permission of Fleetwood Urban Pty Ltd. All rights reserved.

Conditions of Sale:
Goods to be supplied to the following: [Name of Client]
The Client shall be deemed to have accepted the goods on delivery and shall be liable for any loss or damage to the goods from the date of delivery. The Client shall be responsible for any customs duties and taxes payable on the goods. The Client shall be responsible for any freight charges and insurance costs. The Client shall be responsible for any unloading and stacking charges. The Client shall be responsible for any unloading and stacking charges. The Client shall be responsible for any unloading and stacking charges.

DRAWN BY: DS
SCALE: 1:100
DATE: 19/04/2016

CLIENT: WOLLONDILLY SHIRE COUNCIL

ARCHITECT: FLEETWOOD URBAN
Fleetwood

PROJECT: RACECOURSE CREEK SPORTSGROUND, PICTON

PRODUCT: STIRLING™ BRIDGE

3D PRODUCT DRAWING

9157 **03**

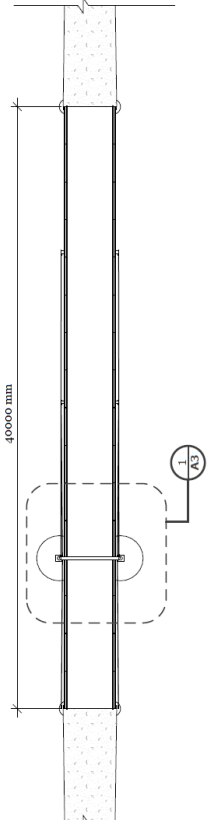

PLAN
SCALE: 1:1250

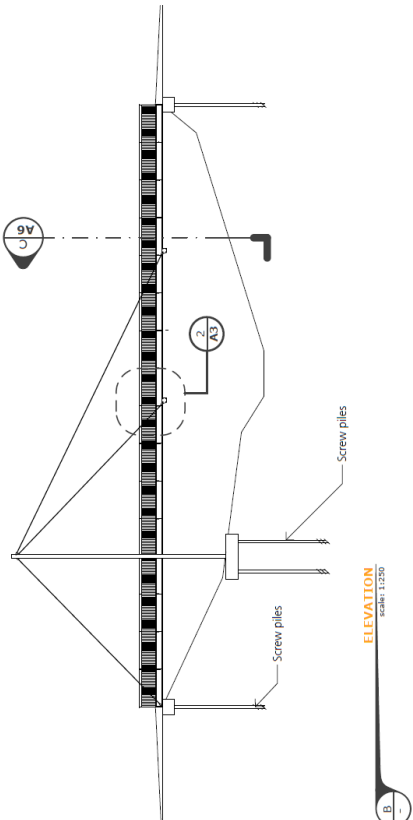

ELEVATION
SCALE: 1:1250

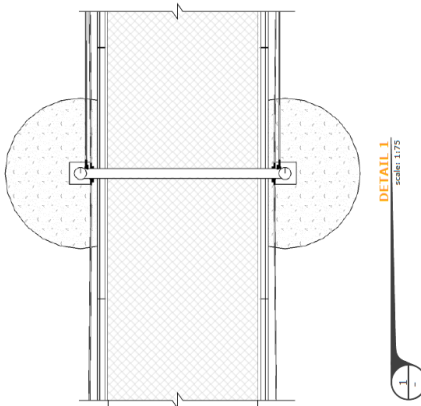

DETAIL 1
SCALE: 1:175

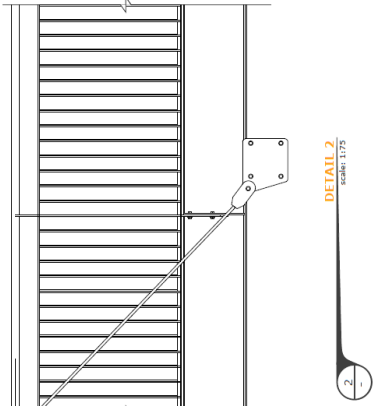

DETAIL 2
SCALE: 1:175

IN3 – Tender 2016/06 Picton Sportsground Pedestrian Bridge Design and Construct

ATTACHMENT 1 – 8966 – 16 MAY 2016



Fleetwood
Fleetwood Urban Pty Ltd
www.fleetwoodurban.com.au
Ph: 1300 359 110



*Inspirational
Communities*

© 2015 Fleetwood Urban Pty Ltd. No part of this drawing may be reproduced, stored in a retrieval system, or transmitted in any form or by any means, electronic, mechanical, photocopying, recording, or otherwise, without the prior written permission of Fleetwood Urban Pty Ltd. All rights in this respect are reserved.

Confidential Property. This drawing contains confidential information. It is to be used only for the purposes stated. It is not to be copied, altered, or otherwise used without the prior written permission of Fleetwood Urban Pty Ltd. It is to be returned upon request.

Graphical representation of product to be shown. All dimensions are indicated and they reflect actual conditions.

DRAWN BY
DS

ISSUE
19/04/2016

CLIENT
WOLLONDILLY SHIRE
COUNCIL

ARCHITECT
FLEETWOOD URBAN

PROJECT
RACECOURSE CREEK
SPORTSGROUND, PICTON

PRODUCT
STIRLING™ BRIDGE

3D PRODUCT DRAWING

04
9157

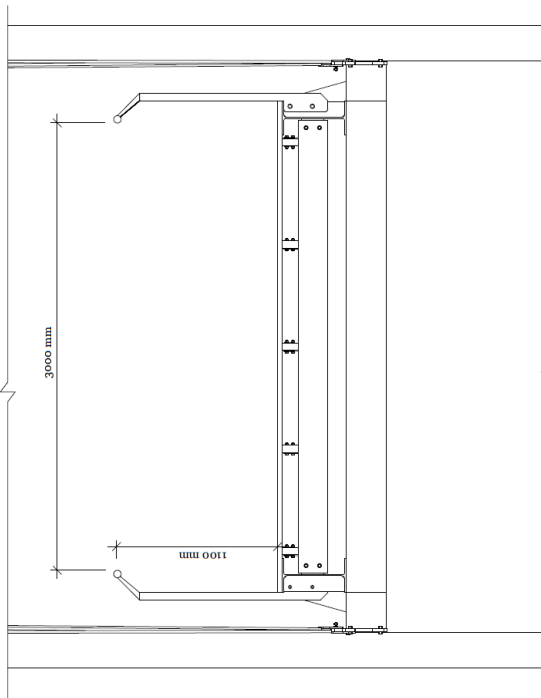

SECTION
SECTION 1/25

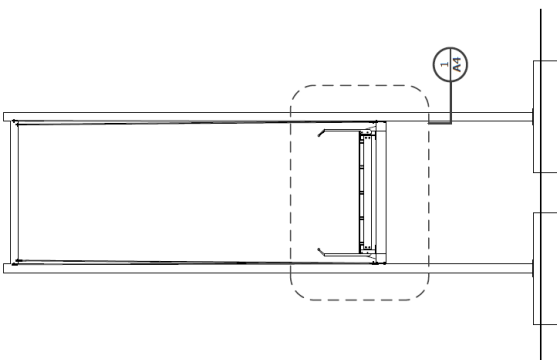

SECTION
SECTION 1/100