

The background of the page is a photograph of several Grey-headed Flying-foxes (Pteropus poliocephalus) hanging upside down from tree branches. The bats have dark wings and a greyish-brown head, with some showing a reddish-brown patch on their chest. They are surrounded by green leaves and branches.

Stonequarry Creek, Picton, Grey Headed Flying-fox **Camp Management Plan**

January 2018

Wollondilly Shire Council

Acknowledgements

We acknowledge input by the NSW Office of Environment and Heritage, and consultants Ecosure, in developing the template on which this Camp Management Plan was based. Peggy Eby also provided advice which was included in the template.

Contents

Acknowledgements	ii
Acronyms and abbreviations	vi
1. Overview	1
1.1 Objectives	1
2. Context Camp Location	2
MAP 1 Camp Location	2
MAP 2 Regional Flying Fox camp Locations	3
2.1 Camp area	4
2.1 Camp area	4
2.1.1 History of the camp	4
2.2 Land tenure	5
2.3 Reported issues related to the camp	5
2.4 Management response to date	6
3. Community engagement	7
3.1 Online Survey	7
3.2 Community feedback – management options	8
4. Legislation and policy	9
4.1 State	9
4.1.1 Flying-fox Camp Management Policy 2015	9
4.1.2 <i>Threatened Species Conservation Act 1995</i>	9
4.1.3 <i>National Parks and Wildlife Act 1974</i>	9
4.1.4 <i>Biodiversity Conservation Act 2015</i>	10
4.1.5 <i>Local Government Act 1993</i>	10
4.1.4 <i>Prevention of Cruelty to Animals Act 1979</i>	10
4.1.5 <i>Environmental Planning and Assessment Act 1979</i>	10
4.2 Commonwealth	10
4.2.1 <i>Environment Protection and Biodiversity Conservation Act 1999</i>	10
5. Other ecological values of the site	12
5.1 Desktop Assessment	13
5.2 Field Assessment	13
6. Flying-fox ecology and behaviour	18
6.1 Ecological role	18
6.2 Flying-foxes in urban areas	18
6.3 Under threat	19
6.4 Camp characteristics	19
6.5 Species profiles - Grey-headed flying-fox (<i>Pteropus poliocephalus</i>)	20

7. Human and animal health	21
7.1 Disease and flying-fox management	21
8. Camp management options	22
8.1 Level 1 actions: routine camp management	22
8.1.1 Education and awareness programs	22
8.1.2 Property modification without subsidies	22
8.1.3 Property modification subsidies	23
8.1.4 Service subsidies	23
8.1.5 Routine camp maintenance and operational activities	23
8.1.6 Revegetation and land management to create alternative habitat	24
8.1.7 Provision of artificial roosting habitat	24
8.1.8 Protocols to manage incidents	24
8.1.9 Participation in research	25
8.1.10 Appropriate land-use planning	25
8.1.11 Property acquisition	25
8.1.12 Do nothing	25
8.2 Level 2 actions: in-situ management	25
8.2.1 Buffers	25
8.2.2 Noise attenuation fencing	26
8.3 Level 3 actions: disturbance or dispersal	26
8.3.1 Nudging	26
8.3.2 Dispersal	27
8.4 Unlawful activities	28
8.4.1 Culling	28
8.5 Site-specific analysis of camp management options	30
9. Planned management approach	35
MAP 4 Potential Management Zones	36
9.1 Stop work triggers	39
10. Assessment of impacts to flying-foxes	39
10.1 Regional context	39
10.2 Flying-fox habitat to be affected	39
10.3 Assessment of impacts to other threatened species or communities	42
10.4 Measures to avoid impacts	40
10.4.1 All management activities	40
10.4.2 All Level 2 actions	41
10.4.3 Vegetation trimming/removal	42
10.4.4 Bush regeneration	43

11. Evaluation and review	44
12. Plan administration	46
12.1 Monitoring of the camp	46
12.2 Reporting	46
12.3 Management structure and responsibilities	46
12.4 Adaptive management	48
12.5 Funding commitment	48
13. References and additional resources	49
Appendix 1: Living with flying foxes fact sheet.	56
Appendix 2: Summary of other key legislation likely to apply at some camps	Error!
Bookmark not defined.	58
Appendix 3: Flora and fauna records (NSW Bionet)	60
Appendix 4: EPBC Act Protected Matters Search report	67
Appendix 5: Additional human and animal health information	80
Appendix 6: Expert assessment requirements	82
Appendix 7: Dispersal results summary	83
Appendix 8: Odour neutralising information	85

Acronyms and abbreviations

ABLV	Australian bat lyssavirus
BFF	black flying-fox (<i>Pteropus alecto</i>)
DoE	Commonwealth Department of the Environment
DPI	Department of Primary Industries (NSW)
EP&A Act	<i>Environmental Planning and Assessment Act 1979</i> (NSW)
EPA	Environment Protection Authority (NSW)
EPBC Act	<i>Environment Protection and Biodiversity Conservation Act 1999</i> (Commonwealth)
GHFF	grey-headed flying-fox (<i>Pteropus poliocephalus</i>)
the Guideline	Referral guideline for management actions in grey-headed and spectacled flying-fox camps 2015 (Commonwealth)
HeV	Hendra virus
LGA	local government area
LGNSW	Local Government NSW
LRFF	little red flying-fox (<i>Pteropus scapulatus</i>)
MNES	matters of national environmental significance
NPW Act	<i>National Parks and Wildlife Act 1974</i> (NSW)
NPWS	National Parks and Wildlife Service (NSW)
OEH	Office of Environment and Heritage (NSW)
PEPs	protection of the environment policies
the Plan	Camp Management Plan
POEO Act	<i>Protection of the Environment Operations Act 1997</i> (NSW)
the Policy	Flying-fox Camp Management Policy 2015 (NSW)
SEPPs	State Environmental Planning Policies
SIS	species impact statement
TEC	threatened ecological community
TSC Act	<i>Threatened Species Conservation Act 1995</i> (NSW)

1. Overview

1.1 Objectives

The objectives of this Camp Management Plan (the Plan) are to:

- minimise impacts to the community, while conserving flying-foxes and their habitat
- provide a reasonable level of amenity for the surrounding community
- manage public health and safety risks
- clearly define roles and responsibilities
- enable land managers and other stakeholders to use a range of suitable management responses to sustainably manage flying-foxes
- effectively communicate with stakeholders during planning and implementation of management activities
- enable long-term conservation of flying-foxes within the shire
- ensure management is sympathetic to flying-fox behaviours and requirements
- improve community understanding and appreciation of flying-foxes, including their critical ecological role
- ensure flying-fox welfare is a priority during all works
- ensure camp management is consistent with broader conservation management strategies that may be developed to protect threatened species/communities
- ensure camp management does not contribute to loss of biodiversity or increase threats to threatened species/communities
- clearly outline the camp management actions that have been approved and will be utilised at the camp
- ensure management activities are consistent with the NSW Flying-fox Camp Management Policy (OEH 2015b)
- facilitate licence approval (where required) for actions at the camp
- implement an adaptive management approach to camp management based on evidence collected.

2. Camp Location

Map 1

The Stonequarry Creek flying fox camp is located to the south of Picton town ship within the Wollondilly Shire, 90km south west of Sydney, NSW. The camp is located within a steep riparian corridor along the banks of Stonequarry Creek and the camp area crosses a number of private residential lots and crown water reserve.

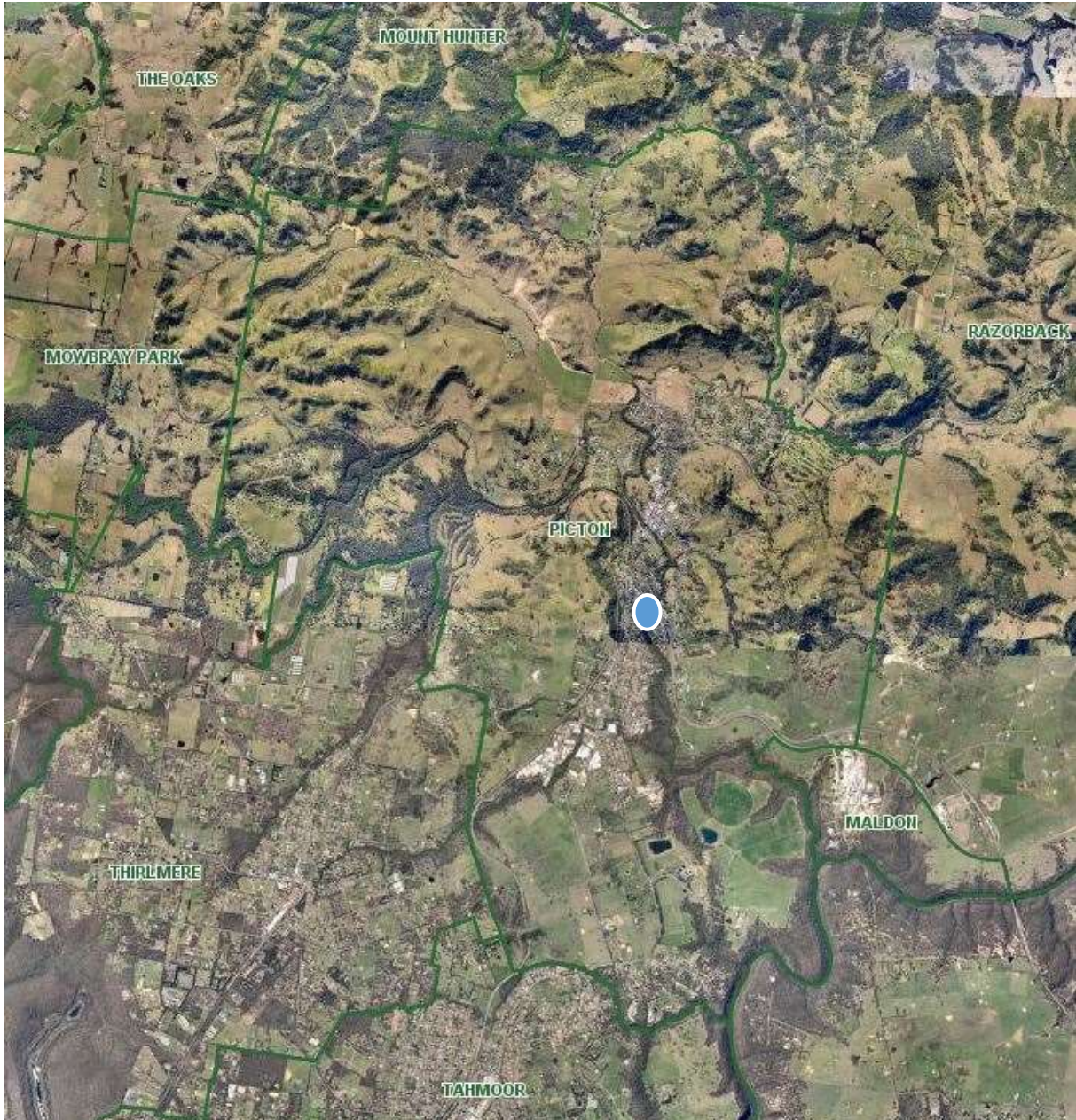

Stonequarry Creek Flying-fox Camp Management Plan

Map 2

Regional flying fox camp locations

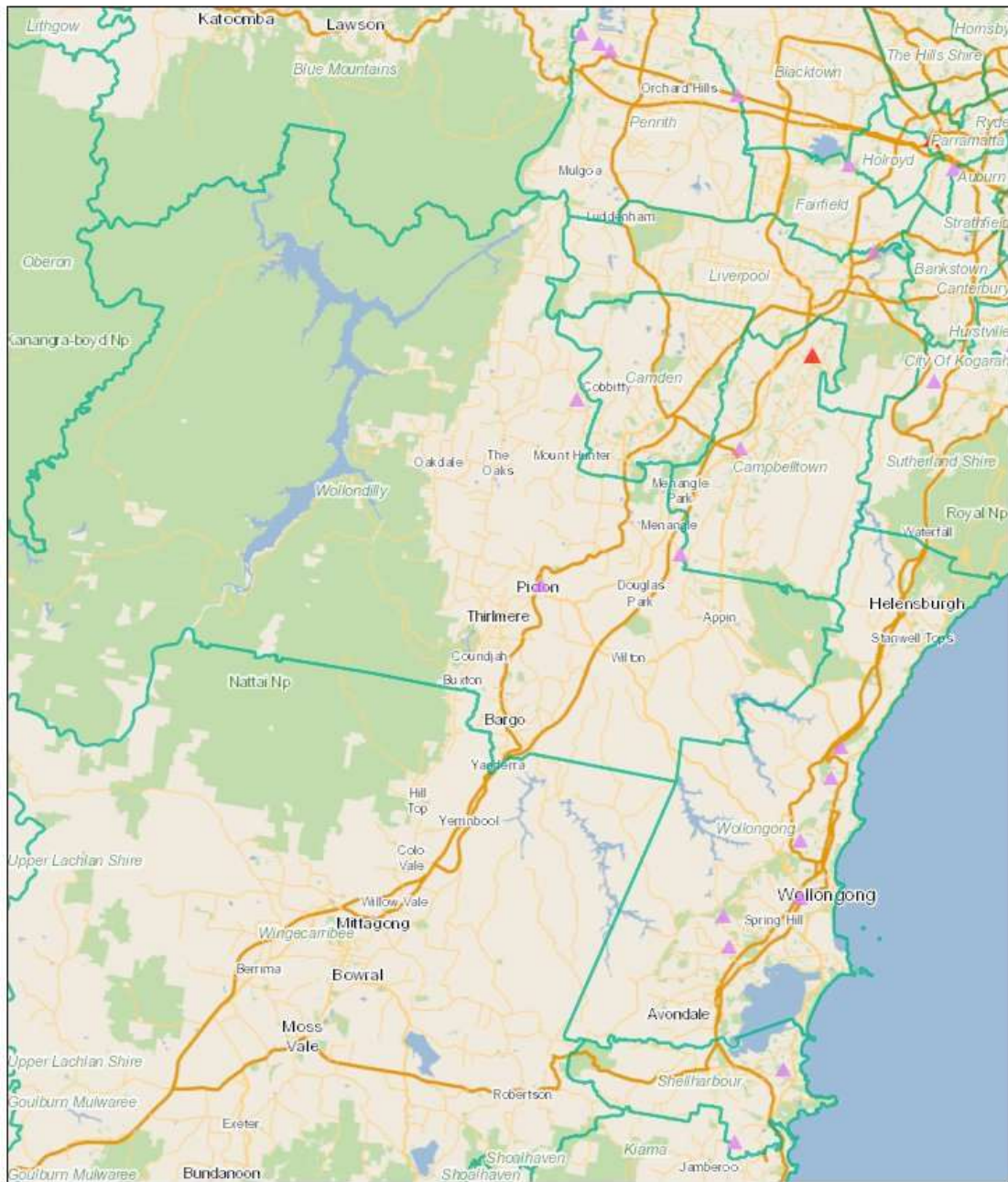

December 12, 2016

- ▲ Nationally Important Flying-fox Camp
- ▲ Other Flying-fox Camp
- Local Government Areas

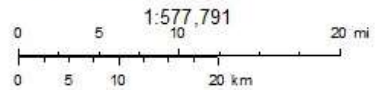

Map produced by the Department of the Environment
© Commonwealth of Australia (Geoscience Australia) 2013
© PSMA Australia Limited 2013

2.1 Camp area

The camp is located on Stonequarry Creek between the railway Viaduct, at the end of Webster St., and the Prince St. Bridge, Picton (refer to map 3 below).

The vegetation of the area is River-Flat Eucalypt Forest with high levels of weed infestation primarily of privet, moth vine and honeysuckle.

The maximum area the camp has covered is 3.3 Ha, however the extent of the camp varies seasonally and from year to year.

Map 3 Area of camp.

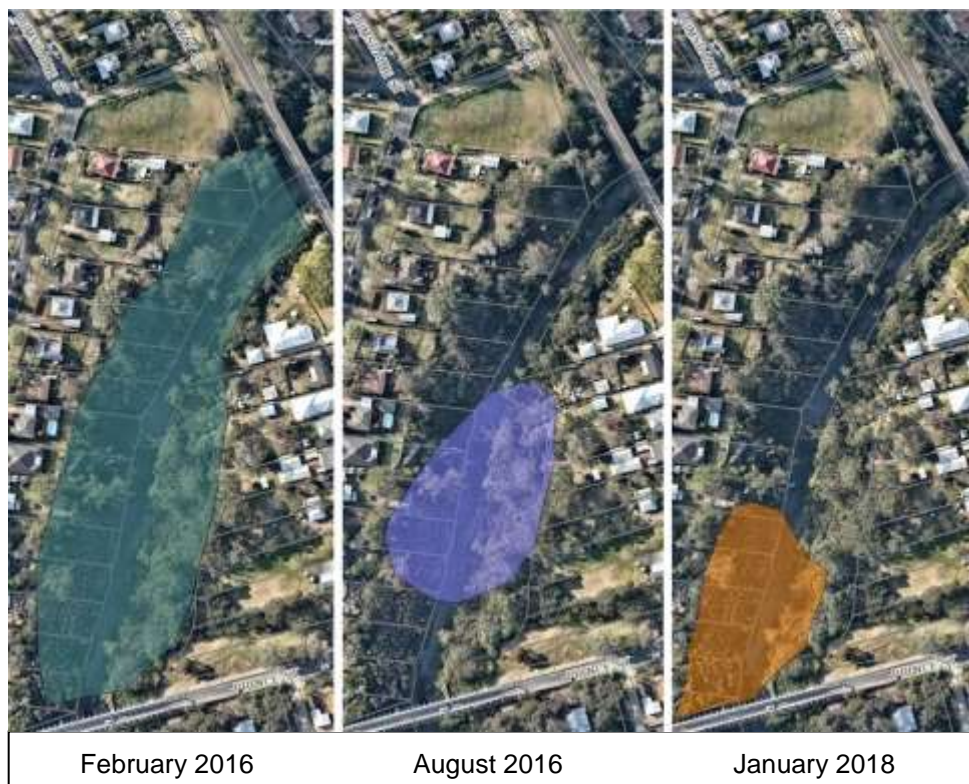

2.1.1 History of the camp

The camp was first recorded in February 2014 and is seasonally occupied by the Grey Headed Flying Fox (GHFF). In 2014 when the camp was first sighted it was restricted to the northern half of the blue area noted in the map 3. The camp then expanded in 2015/2016 to cover the whole area and the number of flying-foxes recorded at the camp was ~6,000 in February 2016. This then decreased to being empty in May 2016.

The camp is currently covering approximately .5Ha with ~ 8,500 flying foxes as of November 2017.

Council staff undertake regular flying fox counts in accordance with the national monitoring methodology developed by the CSIRO and input the data collected into the national flying fox monitoring website.

The reasons for the establishment of the camp are not clear. Anecdotally the Stonequarry Creek flying fox camp seemed to establish not long after the Halls Road Fire which occurred in October 2013. This fire was quite extensive and burnt out some 15,600 Ha of bushland between Balmoral, Bargo, Yanderra, Picton and Wilton and may have burnt out previously existing habitat.

Stonequarry Creek Flying-fox Camp Management Plan

Summer of 2013/2014 was quite hot and dry and the area where the camp established on Stonequarry Creek is quite sheltered in a steep gully with thick vegetation of Privet which provides for cooler temperature during the day.

As such there are very few food trees within the camp area so the colony must leave in the evenings to source food. This is likely causing issues in other areas within the shire particularly around orchard and farm lands.

The Office of Environment and Heritage have also reported a state wide shortage of food for the flying foxes which may be another factor that has driven them into the Picton area.

2.2 Land tenure

The camp area covers 26 privately owned residential lots which are zoned R2 Low Density Residential and also Crown water reserve along the creek. The site is bounded by a Transport NSW, rail corridor to the north and The Prince St. Bridge to the south. Council does not own any land within the camp area.

2.3 Reported issues related to the camp

Since council became aware of the extent camp in February 2014 the camp has at times swelled to over 10,000 triggering a number of concerns and issues raised by local residents who live near the camp.

Reported issues include:

- Noise of flying-foxes particularly when they fly out at dusk and return in the early hours of the morning.
- Faecal drop over residences, driveways, cars, clothes lines, outdoor furniture and play equipment.
- Odour from the camp noted being very strong April / May 2015 when camp numbers were in excess of 5,000.
- Fear of potential health risks and pets getting sick from contact with the flying foxes.
- Concern that drinking water could be contaminated as a number of residents drink filtered rainwater captured from their roof.
- Health and/or wellbeing impacts (e.g. associated with lack of sleep, anxiety).

The majority of issues related to the camp are recorded later spring to late summer which tends to coincide with increase in numbers of flying-foxes, during hotter months.

At times of high occupation, there is potential for a dispersed impact across broad areas of the shire, used for foraging, and on residential land. This is primarily associated with faecal drop and feeding on residential properties.

It has also been reported that there has been an increased impact on local commercial orchards.

10 local residents have reported a number of issues / concerns about the camp in the past 2 years. This represents 15% of the total population living within 300m of the camp.

There has also been feedback from residents in the surrounding area who enjoy the camp and have expressed the difficulty in conserving the endangered GHFF whilst supporting the local community with their concerns.

Positive feedback has come from the community in the interests of:

- Recognise the landscape-scale benefits flying-foxes provide through seed dispersal and pollination
- Acknowledge the need to conserve flying-foxes as an important native species
- Appreciate the natural values of the camp and habitat

Stonequarry Creek Flying-fox Camp Management Plan

- Recognise the need for people and wildlife to live together.

2.4 Management response to date

Council have fielded community concerns and questions about the camp which have been considered within this plan. At this stage no practical management actions have been carried out on the camp by council because the camp occurs primarily on private land and a portion crown water land. Council is awaiting endorsement of this plan from The Office of Environment and Heritage before any management actions will proceed.

3. Community engagement

A variety of efforts have been made to engage with the community regarding the flying-fox camp to:

- understand the issues directly and indirectly affecting the community
- raise awareness within the community about flying-foxes
- correct misinformation and allay fears
- share information and invite feedback about management responses to date
- seek ideas and feedback about possible future management options

The types of engagement that have been undertaken include:

- 'Living near Flying Foxes' fact sheet has been produced and is available on Council's website. See appendix 1 for information.
- promotion of contact details of responsible officers
- telephone conversations to record issues and complaints
- telephone calls with adjacent residents
- media (radio, television, print, social media)
- website pages and links
- direct contact with adjacent residents including letters, brochures and emails

3.1 Online survey

Wollondilly Shire Council undertook a community survey in January / February 2017. This time of year is generally when the camp is at its largest size. A flyer was delivered to over 50 residents neighbouring the Stonequarry Creek Flying Fox camp on Campbell St, Lumsdaine St, Webster St, Prince St and Picton Avenue.

The flyer contained information outlining the location of the camp, online links to the survey and other information including FAQ's, the fact sheet "Living near Flying Foxes" and the contact details for council officers who can answer enquiries about the camp.

We had a 15% response rate to the survey with the main concerns being noise, odour, the impact of droppings and potential health risks.

The key results from the survey were:

- 87% of the respondents identified that the odour from the camp had an important to extremely important impact on their household.
- 87% of the respondents identified that excrement had an important to extremely important impact on their household.
- Respondents identified the following direct impacts as follows.
 - Clothes line 71%
 - Disturbed sleep 57%
 - Car 57%
 - Rainwater Tanks 43%
 - Trees 43%
 - Driveway / Outdoor Area 29%
 - Swimming Pool 14%
- 67% of respondents identified the impacts of the camp were mainly during spring and summer.

3.2 Community feedback – management options

There were a number of suggestions provided by the community through the online survey about how council can best manage the camp into the future.

The most common request has been to try and move the flying fox camp elsewhere i.e., nudging or dispersal. This action has been considered as part of the CMP with more detail in sections 8.3.1 and Appendix 7. In summary previous attempts to disperse flying fox camps in other areas have proven to be expensive and generally unsuccessful. This action requires licencing approval from the Office of Environment and Heritage and is generally a last resort after other camp management actions have been implemented.

Trimming and controlling privet in the camp area has been suggested as a way to help manage the extent of the camp. The CMP has identified this as a priority action with more detail provided in section 8.2.1. Any vegetation works undertaken within the camp area will also need to be approved by the Office of Environment and Heritage and must adhere to the Vegetation Management Plan (VMP) that will also be developed for the site.

Community education about the health risks of coming into contact with flying foxes. Council has produced the 'living near flying foxes' brochure which is available on council's website and also as Appendix 1 within this plan. Section 7 and Appendix 5 also have detail information about the human and animal health risks of coming into contact with flying foxes. In summary disease is only transferred from flying foxes through being scratched or bitten so avoid physical contact with the animals. If you find an injured flying fox please contact Wollondilly WIRES.

4. Legislation and policy

4.1 State

At the time of Plan development, a reform to conservation and land management in NSW was underway. This includes planned repeal of the *Threatened Species Conservation Act 1995* and *National Parks and Wildlife Act 1974*, which will be replaced by the consolidated *Biodiversity Conservation Act 2016*. The Office of Environment and Heritage (OEH) will be undertaking further consultation in the later part of 2017 to review and update the 2015 Flying-fox Camp Management Policy.

4.1.1 Flying-fox Camp Management Policy 2015

The Flying-fox Camp Management Policy 2015 (the Policy) has been developed to empower land managers, primarily local councils, to work with their communities to manage flying-fox camps effectively. It provides the framework within which OEH will make regulatory decisions. In particular, the Policy strongly encourages local councils and other land managers to prepare Camp Management Plans for sites where the local community is affected. The Policy outlines a hierarchical approach to management, where low impact management options (Level 1, and Level 2 if required) should be implemented before more invasive measures are considered (Level 3) (see Section 8).

4.1.2 Threatened Species Conservation Act 1995

This Act was repealed on 25 August 2017

4.1.3 National Parks and Wildlife Act 1974

The *National Parks and Wildlife Act 1974* (NPW Act) provides for the conservation of nature, objects, places or features of cultural value and the management of land reserved under this Act. All native animals and many species of native plants are protected under the NPW Act. All native fauna, including flying-foxes, are specifically protected under section 98.

Under this Act, licences can be issued for actions such as harming or obtaining any protected fauna for specified purposes, picking protected plants or damaging habitat of a threatened species, population or ecological community. Note that the definition of 'harm' includes to *hunt, shoot, poison, net, snare, spear, pursue, capture, trap, injure or kill*. The definition of 'pick' includes to *gather, pluck, cut, pull up, destroy, poison, take, dig up, crush, trample, remove or injure the plant or any part of the plant*.

4.1.4 Biodiversity Conservation Act 2016

A threatened species licence, a class of biodiversity conservation licence under Part 2 of the Biodiversity Conservation Act 2016 (BC Act), may be required if an action is likely to result in:

- Harm to an animal that is a threatened species or part of an ecological community
- Picking a plant that is a threatened species or part of an ecological community
- Damage to a habitat of a threatened species or ecological community
- Damage to a declared area of outstanding biodiversity conservation value

As works within the camp proposed by the plan may result in harm to GHFF or damage to their habitat, a threatened species licence will be sort from OEH.

4.1.5 Local Government Act 1993

The primary purpose of this Act is to provide the legal framework for an effective, efficient and environmentally responsible, open system of local government. Most relevant to flying-fox management is that it also provides encouragement for the effective participation of local communities in the affairs of local government and sets out guidance on the use and management of community land which may be applicable to land which requires management of flying-foxes.

4.1.6 Prevention of Cruelty to Animals Act 1979

It may be an offence under this Act if there is evidence of unreasonable/unnecessary torment associated with management activities. Adhering to welfare and conservation measures provided in Section 10.3 will ensure compliance with this Act.

4.1.7 Environmental Planning and Assessment Act 1979

The objects of the *Environmental Planning and Assessment Act 1979* (EP&A Act) are to encourage proper management, development and conservation of resources, for the purpose of the social and economic welfare of the community and a better environment. It also aims to share responsibility for environmental planning between different levels of government and promote public participation in environmental planning and assessment.

The EP&A Act is administered by the NSW Department of Planning and Environment.

Development control plans under the Act should consider flying-fox camps so that planning, design and construction of future developments is appropriate to avoid future conflict.

Development under Part 4 of the Act does not require licensing under the BC Act.

Where public authorities such as local councils undertake development under Part 5 of the EP&A Act (known as 'development without consent' or 'activity'), assessment and licensing under the BC Act may not be required. However a full consideration of the development's potential impacts on threatened species will be required in all cases.

Where flying-fox camps occur on private land, land owners are not eligible to apply for development under Part 5 of the EP&A Act. Private land owners should contact Council to explore management options for camps that occur on private land.

4.2 Commonwealth

4.2.1 Environment Protection and Biodiversity Conservation Act 1999

The Commonwealth's *Environment Protection and Biodiversity Conservation Act 1999* (EPBC Act) provides protection for the environment, specifically matters of national environmental significance (MNES). A referral to the Commonwealth DoE is required under the EPBC Act for any action that is likely to significantly impact on an MNES.

MNES under the EPBC Act that relate to flying-foxes include:

- world heritage sites (where those sites contain flying-fox camps or foraging habitat)
- wetlands of international importance (where those wetlands contain flying-fox camps or foraging habitat)
- nationally threatened species and ecological communities.

The GHFF is listed as a vulnerable species under the EPBC Act, meaning it is an MNES. It is also considered to have a single national population. DoE has developed the [Referral](#)

[guideline for management actions in GHFF and SFF¹ camps](#) (DoE 2015) (the Guideline) to guide whether referral is required for actions pertaining to the GHFF. Referral is more likely required at camps that have been identified as nationally important to one of these threatened species. Management at these nationally important camps should follow mitigation standards in the Guideline to minimise the likelihood of a significant impact to the population.

The Guideline defines a nationally important GHFF camp as one that has either:

- contained $\geq 10,000$ GHFF in more than one year in the last 10 years, or
- been occupied by more than 2500 GHFF permanently or seasonally every year for the last 10 years.

Mitigation standards

- The action must not occur if the camp contains females that are in the late stages of pregnancy or have dependent young that cannot fly on their own.
- The action must not occur during or immediately after climatic extremes (heat stress event², cyclone event³), or during a period of significant food stress⁴.
- Disturbance must be carried out using non-lethal means, such as acoustic, visual and/or physical disturbance or use of smoke.
- Disturbance activities must be limited to a maximum of 2.5 hours in any 12 hour period, preferably at or before sunrise or at sunset.
- Trees are not felled, lopped or have large branches removed when flying-foxes are in or near to a tree and likely to be harmed.
- The action must be supervised by a person with knowledge and experience relevant to the management of flying-foxes and their habitat, who can identify dependent young and is aware of climatic extremes and food stress events. This person must make an assessment of the relevant conditions and advise the proponent whether the activity can go ahead consistent with these standards.
- The action must not involve the clearing of all vegetation supporting a nationally-important flying-fox camp. Sufficient vegetation must be retained to support the maximum number of flying-foxes ever recorded in the camp of interest.

At the time of writing, the Stonequarry Creek camp does not meet the criteria for nationally important camps. However these standards have been incorporated into mitigation measures detailed in Section 10.3 where possible as best practice.

A summary of additional key legislation which may apply to this Plan is provided in Appendix 2.

¹ spectacled flying-fox (*P. conspicillatus*)

² A 'heat stress event' is defined for the purposes of the Australian Government's [Referral guideline for management actions in GHFF and SFF camps](#) as a day on which the maximum temperature does (or is predicted to) meet or exceed 38°C.

³ A 'cyclone event' is defined as a cyclone that is identified by the Australian Bureau of Meteorology (www.bom.gov.au/cyclone/index.shtml).

⁴ Food stress events may be apparent if large numbers of low body weight animals are being reported by wildlife carers in the region.

5. Other ecological values of the site

5.1 Desktop assessment

A search of the NSW Bionet database returned 25 threatened fauna and 15 threatened flora species confirmed within 5 km of Stonequarry Creek camp (Appendix 3).

A 10 km EPBC Act Protected Matters Search Tool (PMST) returned 46 species listed as threatened under the EPBC Act, including 15 migratory species (Appendix 4). The search also returned nine threatened ecological communities (TECs) as potentially occurring within 10 km of the site.

The NSW BioNet search provides actual records of threatened species, while the EPBC Act PMST returns all species possibly occurring. As a result, only the BioNet records have been discussed in relation to their likelihood of occurrence (see Appendix 3). Based on species ecology, plant community types at the site and urban location it was determined 15 fauna and nine flora species could possibly occur at the site (Appendix 3).

Aside from the GHFF, no threatened species were recorded during the field assessment (Section 5.2).

5.2 Field assessment

Flora

A flora assessment of the Picton flying-fox camp was undertaken on 25th July 2017, focussing on the area between the railway viaduct and Victoria Bridge (the camp extent). Searches were undertaken for the 15 threatened flora species based on the 5 km BioNet search, including the nine possibly occurring species. In total, 59 flora species were recorded. Of these, 23 were native species while the remaining 36 were exotic species (Table 1). Dominant native species across the site include Broad-leaved Apple (*Angophora floribunda*), Forest Red Gum (*Eucalyptus tereticornis*) and River Oak (*Casuarina cunninghamiana*). In places the mid-storey is dominated by Large-leaved Privet (*Ligustrum lucidum*) with small patches of Kanooka (*Tristaniopsis laurina*).

Vegetation is mapped as River Flat Eucalypt Forest, a NSW TEC dominated by Forest Red Gum (*Eucalyptus tereticornis*) and Rough-barked Apple (*Angophora floribunda*). The vegetation was ground-truthed during the site assessment and was found to be consistent with this TEC.

Table 1 Picton flying fox camp flora species recorded during site assessment

Family name	Scientific name	Exotic	Common name
Adiantaceae	<i>Adiantum aethiopicum</i>		Common Maidenhair
Apocynaceae	<i>Araujia sericifera</i>	*	Moth Vine
	<i>Gomphocarpus fruticosus</i>	*	Narrow-leaved Cotton Bush
	<i>Vinca major</i>	*	Periwinkle
Asparagaceae	<i>Asparagus aethiopicus</i>	*	Asparagus Fern
	<i>Asparagus asparagoides</i>	*	Bridal Creeper
Asteraceae	<i>Ageratina adenophora</i>	*	Crofton Weed
	<i>Bidens pilosa</i>	*	Cobbler's Pegs

Stonequarry Creek Flying-fox Camp Management Plan

Family name	Scientific name	Exotic	Common name
	<i>Cirsium vulgare</i>	*	Spear Thistle
	<i>Conyza sumatrensis</i>	*	Tall fleabane
	<i>Delairea odorata</i>	*	Cape Ivy
	<i>Hypochaeris radicata</i>	*	Catsear
	<i>Onopordum acanthium subsp. acanthium</i>	*	Scotch Thistle
	<i>Senecio madagascariensis</i>	*	Fireweed
Basellaceae	<i>Anredera cordifolia</i>	*	Madeira Vine
Caprifoliaceae	<i>Lonicera japonica</i>	*	Japanese Honeysuckle
Casuarinaceae	<i>Allocasuarina littoralis</i>		Black She-Oak
	<i>Casuarina cunninghamiana subsp. cunninghamiana</i>		River Oak
Commelinaceae	<i>Tradescantia fluminensis</i>	*	Wandering Jew
Convolvulaceae	<i>Dichondra repens</i>		Kidney Weed
Crassulaceae	<i>Bryophyllum delagoense</i>	*	Mother of millions
Dennstaedtiaceae	<i>Pteridium esculentum</i>		Bracken
Euphorbiaceae	<i>Euphorbia peplus</i>	*	Petty Spurge
Fabaceae	<i>Glycine clandestina</i>		Twining glycine
	<i>Hardenbergia violacea</i>		False Sarsaparilla
	<i>Acacia decurrens</i>		Black Wattle
Juncaceae	<i>Juncus usitatus</i>		
Lauraceae	<i>Cinnamomum camphora</i>	*	Camphor Laurel
Lomandraceae	<i>Lomandra longifolia</i>		Spiny-headed Mat-rush
	<i>Lomandra multiflora subsp. multiflora</i>		Many-flowered Mat-rush
Luzuriagaceae	<i>Geitonoplesium cymosum</i>		Scrambling Lily
Myrsinaceae	<i>Lysimachia arvensis</i>	*	Scarlet Pimpernel
Myrtaceae	<i>Angophora floribunda</i>		Rough-barked Apple
	<i>Eucalyptus tereticornis</i>		Forest Red Gum
	<i>Lophostemon confertus</i>		Brush Box
	<i>Tristaniopsis laurina</i>		Kanooka
Oleaceae	<i>Ligustrum lucidum</i>	*	Large-leaved Privet
	<i>Ligustrum sinense</i>	*	Small-leaved Privet
	<i>Olea europaea subsp. cuspidata</i>	*	African Olive
Phytolaccaceae	<i>Phytolacca octandra</i>	*	Inkweed
Poaceae	<i>Bambusa sp.</i>	*	Giant bamboo
	<i>Cortaderia selloana</i>	*	Pampas Grass
	<i>Paspalum dilatatum</i>	*	Paspalum

Stonequarry Creek Flying-fox Camp Management Plan

Family name	Scientific name	Exotic	Common name
	<i>Pennisetum clandestinum</i>	*	Kikuyu Grass
Proteaceae	<i>Grevillea robusta</i>		Silky Oak
Sapindaceae	<i>Dodonaea pinnata</i>		
Solanaceae	<i>Solanum mauritianum</i>	*	Wild Tobacco Bush
	<i>Solanum nigrum</i>	*	Black-berry Nightshade
Urticaceae	<i>Urtica incisa</i>		Stinging Nettle
Verbenaceae	<i>Lantana camara</i>	*	Lantana
	<i>Verbena quadrangularis</i>	*	
Poaceae	<i>Arundo donax</i>	*	Giant Reed
	<i>Briza maxima</i>	*	Quaking Grass
	<i>Chloris gayana</i>	*	Rhodes Grass
	<i>Chloris ventricosa</i>		Tall Chloris
	<i>Cynodon dactylon</i>		Common Couch
	<i>Imperata cylindrica</i>		Blady Grass
	<i>Microlaena stipoides</i>		Weeping Grass
Solanaceae	<i>Cestrum parqui</i>	*	Green Cestrum

At the time of the survey the flying-fox camp was located in a dense stand of Large-leaved Privet immediately south of Victoria Bridge. The majority of flying-foxes were roosting at the same level as the bridge or just below. Privet is the dominant roost tree, particularly along the middle and upper reaches of the creek banks.

There is a profusion of weeds, 36 species in total, along the banks of Stonequarry Creek where they dominate the lower, mid and upper storey stratum. Many of these exotics have outcompeted native regrowth following extensive tree clearing on both sides of the creek. There is some evidence of land slippage as a result of vegetation removal. There are a number of residential properties which back on to the banks of Stonequarry Creek, with the result that several garden plants have established on the western and eastern banks including Pampas Grass (*Cortaderia selloana*) and Giant Bamboo (*Bambusa sp.*). There are several mature eucalypts between Victoria Bridge and the railway viaduct along the upper banks of Stonequarry Creek, particularly on the upper banks on the eastern side. At the time of the survey these were not being used as camp habitat.

South of the viaduct the Stonequarry Creek Landcare Group have been actively removing weeds from the area and have been successful in restoring some native vegetation. Restoration will be challenging north of the viaduct due to the steep banks and numerous weeds. Existing patches of Kanooka could be restored to replace broad-leaved privet with this native species over time.

Stonequarry Creek Flying-fox Camp Management Plan

Fauna

A list of fauna species observed on the site from the targeted habitat assessment survey and opportunistic sightings is provided in Table 2. Twenty-eight species of bird were observed on the site, comprised mostly of common species found in urban environments. These included the Superb Fairy Wren (*Malurus cyaneus*), Red-browed Finch (*Neochmia temporalis*) and Australian Magpie (*Cracticus tibicen*). No threatened bird species were recorded.

There is a distinct lack of ground dead wood or hollow-bearing trees across the entire site. This poor quality habitat in the lower and mid-storey has created a reduced prey base for a range of insectivorous and nectivorous birds and may partly explain the low diversity of avian species at the site.

Sampling of fallen timber and undergrowth for reptiles revealed only two common skinks; the Dark-flecked Garden Skink (*Lampropholis delicata*) and Eastern Water-skink (*Eulamprus quoyii*). The site survey was undertaken in the middle of winter on a relatively cold day. Targeted surveys during the warmer periods of the year may reveal a range of other reptiles as they become more active.

With the exception of the GHFF, there was very little evidence of mammal activity. Further survey work may reveal a range of other urban species such as the Common Brush-tailed Possum (*Trichosurus vulpecula*) and Common Ringtail Possum (*Pseudocheirus peregrinus*), and potentially threatened species including microbats and Koala (*Phascolarctos cinereus*) use (see Appendix 3).

Table 2 all fauna species recorded during site assessment

Class name	Family name	Scientific name	Exotic	Common name
Amphibia	Myobatrachidae	<i>Crinia signifera</i>		Common Eastern Froglet
	Hylidae	<i>Litoria verreauxii</i>		Verreaux's Frog
Reptilia	Scincidae	<i>Eulamprus quoyii</i>		Eastern Water-skink
		<i>Lampropholis delicata</i>		Dark-flecked Garden Sunskink
Aves	Anatidae	<i>Anas superciliosa</i>		Pacific Black Duck
		<i>Chenonetta jubata</i>		Australian Wood Duck
	Columbidae	<i>Streptopelia chinensis</i>	*	Spotted Turtle-Dove
	Cacatuidae	<i>Cacatua galerita</i>		Sulphur-crested Cockatoo
	Psittacidae	<i>Alisterus scapularis</i>		Australian King-Parrot
		<i>Platycercus elegans</i>		Crimson Rosella
		<i>Platycercus eximius</i>		Eastern Rosella
	Alcedinidae	<i>Dacelo novaeguineae</i>		Laughing Kookaburra
	Climacteridae	<i>Cormobates leucophaea</i>		White-throated Treecreeper
	Maluridae	<i>Malurus cyaneus</i>		Superb Fairy-wren
Acanthizidae	<i>Acanthiza lineata</i>		Striated Thornbill	
Pardalotidae	<i>Pardalotus punctatus</i>		Spotted Pardalote	
Meliphagidae	<i>Manorina melanocephala</i>		Noisy Miner	
	<i>Manorina melanophrys</i>		Bell Miner	

Stonequarry Creek Flying-fox Camp Management Plan

Class name	Family name	Scientific name	Exotic	Common name
		<i>Philemon corniculatus</i>		Noisy Friarbird
	Pachycephalidae	<i>Colluricincla harmonica</i>		Grey Shrike-thrush
	Artamidae	<i>Cracticus tibicen</i>		Australian Magpie
	Rhipiduridae	<i>Rhipidura albiscapa</i>		Grey Fantail
	Corvidae	<i>Corvus coronoides</i>		Australian Raven
	Sturnidae	<i>Sturnus vulgaris</i>	*	Common Starling
	Estrildidae	<i>Neochmia temporalis</i>		Red-browed Finch
Mammalia	Pteropodidae	<i>Pteropus poliocephalus</i>		Grey-headed flying-fox

6. Flying-fox ecology and behaviour

6.1 Ecological role

Flying-foxes, along with some birds, make a unique contribution to ecosystem health through their ability to move seeds and pollen over long distances (Southerton et al. 2004). This contributes directly to the reproduction, regeneration and viability of forest ecosystems (DoE 2016a).

It is estimated that a single flying-fox can disperse up to 60,000 seeds in one night (ELW&P 2015). Some plants, particularly *Corymbia* spp., have adaptations suggesting they rely more heavily on nocturnal visitors such as bats for pollination than daytime pollinators (Southerton et al. 2004).

Grey-headed flying-foxes may travel 100 km in a single night with a foraging radius of up to 50 km from their camp (McConkey et al. 2012), and have been recorded travelling over 500 km in two days between camps (Roberts et al. 2012). In comparison bees, another important pollinator, move much shorter foraging distances of generally less than one kilometre (Zurbuchen et al. 2010).

Long-distance seed dispersal and pollination makes flying-foxes critical to the long-term persistence of many plant communities (Westcott et al. 2008; McConkey et al. 2012), including eucalypt forests, rainforests, woodlands and wetlands (Roberts et al. 2006). Seeds that are able to germinate away from their parent plant have a greater chance of growing into a mature plant (EHP 2012). Long-distance dispersal also allows genetic material to be spread between forest patches that would normally be geographically isolated (Parry-Jones & Augee 1992; Eby 1991; Roberts 2006). This genetic diversity allows species to adapt to environmental change and respond to disease pathogens. Transfer of genetic material between forest patches is particularly important in the context of contemporary fragmented landscapes.

Flying-foxes are considered 'keystone' species given their contribution to the health, longevity and diversity among and between vegetation communities. These ecological services ultimately protect the long-term health and biodiversity of Australia's bushland and wetlands. In turn, native forests act as carbon sinks, provide habitat for other fauna and flora, stabilise river systems and catchments, add value to production of hardwood timber, honey and fruit (e.g. bananas and mangoes; Fujita 1991), and provide recreational and tourism opportunities worth millions of dollars each year (EHP 2012; ELW&P 2015).

6.2 Flying-foxes in urban areas

Flying-foxes appear to be roosting and foraging in urban areas more frequently. There are many possible drivers for this, as summarised by Tait et al. (2014):

- loss of native habitat and urban expansion
- opportunities presented by year-round food availability from native and exotic species found in expanding urban areas
- disturbance events such as drought, fires, cyclones
- human disturbance or culling at non-urban roosts or orchards
- urban effects on local climate
- refuge from predation
- movement advantages, e.g. ease of manoeuvring in flight due to the open nature of the habitat or ease of navigation due to landmarks and lighting.

6.3 Under threat

Flying-foxes roosting and foraging in urban areas more frequently can give the impression that their populations are increasing; however, the grey-headed flying-fox is in decline across its range and in 2001 was listed as vulnerable by the NSW Government through the BC Act.

At the time of listing, the species was considered eligible for listing as vulnerable as counts of flying-foxes over the previous decade suggested that the national population may have declined by up to 30%. It was also estimated that the population would continue to decrease by at least 20% in the next three generations given the continuation of the current rate of habitat loss and culling.

The main threat to grey-headed flying-foxes in NSW is clearing or modification of native vegetation. This threatening process removes appropriate roosting and breeding sites and limits the availability of natural food resources, particularly winter–spring feeding habitat in north-eastern NSW. The urbanisation of the coastal plains of south-eastern Queensland and northern NSW has seen the removal of annually-reliable winter feeding sites, and this threatening process continues.

There is a wide range of ongoing threats to the survival of the GHFF, including:

- habitat loss and degradation
- conflict with humans (including culling at orchards)
- infrastructure-related mortality (e.g. entanglement in barbed wire fencing and fruit netting, power line electrocution, etc.)
- predation by native and introduced animals
- exposure to extreme natural events such as cyclones, drought and heat waves.

Flying-foxes have limited capacity to respond to these threats and recover from large population losses due to their slow sexual maturation, small litter size, long gestation and extended maternal dependence (McIlwee & Martin 2002).

6.4 Camp characteristics

All flying-foxes are nocturnal, roosting during the day in communal camps. These camps may range in number from a few to hundreds of thousands, with individual animals frequently moving between camps within their range. Typically, the abundance of resources within a 20–50 kilometre radius of a camp site will be a key determinant of the size of a camp (SEQ Catchments 2012). Therefore, flying-fox camps are generally temporary and seasonal, tightly tied to the flowering of their preferred food trees. However, understanding the availability of feeding resources is difficult because flowering and fruiting are not reliable every year, and can vary between localities (SEQ Catchments 2012). These are important aspects of camp preference and movement between camps, and have implications for long-term management strategies.

Little is known about flying-fox camp preferences; however, research indicates that apart from being in close proximity to food sources, flying-foxes choose to roost in vegetation with at least some of the following general characteristics (SEQ Catchments 2012):

- closed canopy >5 metres high
- dense vegetation with complex structure (upper, mid- and understorey layers)
- within 500 metres of permanent water source
- within 50 kilometres of the coastline or at an elevation <65 metres above sea level
- level topography (<5° incline)
- greater than one hectare to accommodate and sustain large numbers of flying-foxes.

Optimal vegetation available for flying-foxes must allow movement between preferred areas of the camp. Specifically, it is recommended that the size of a patch be approximately three times the area occupied by flying-foxes at any one time (SEQ Catchments 2012).

6.5 Species profiles

Grey-headed flying-fox (*Pteropus poliocephalus*)

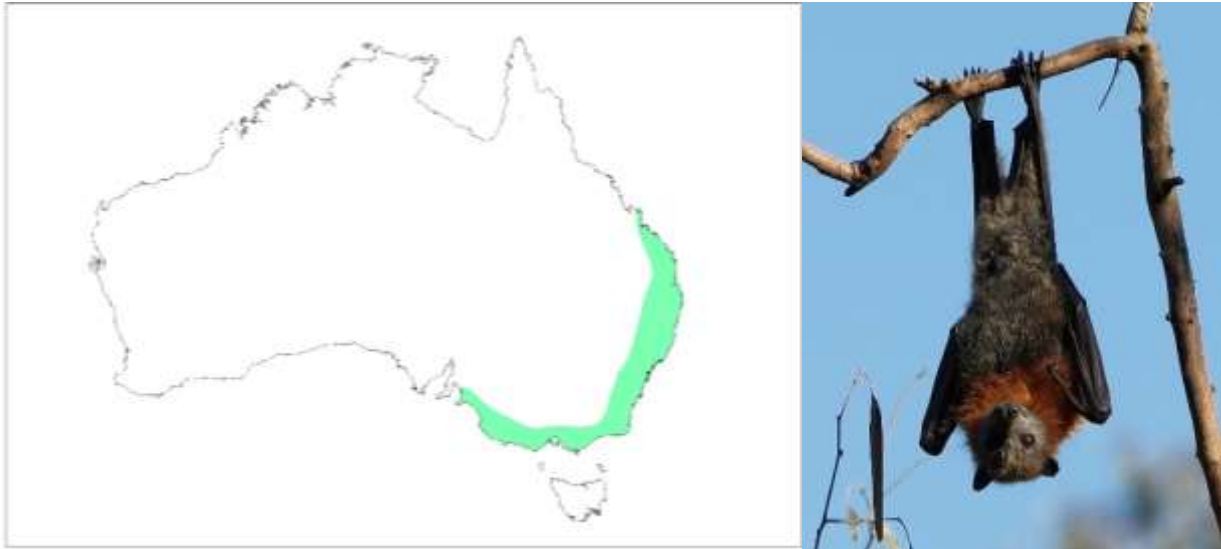

Figure 2: Grey-headed flying-fox indicative species distribution, adapted from OEH 2015a

The grey-headed flying-fox (GHFF) (Figure 2) is found throughout eastern Australia, generally within 200 kilometres of the coast, from Finch Hatton in Queensland to Melbourne, Victoria (OEH 2015d). This species now ranges into South Australia and has been observed in Tasmania (DoE 2016a). It requires foraging resources and camp sites within rainforests, open forests, closed and open woodlands (including melaleuca swamps and banksia woodlands). This species is also found throughout urban and agricultural areas where food trees exist and will raid orchards at times, especially when other food is scarce (OEH 2015a).

All the GHFF in Australia are regarded as one population that moves around freely within its entire national range (Webb & Tidemann 1996; DoE 2015). GHFF may travel up to 100 kilometres in a single night with a foraging radius of up to 50 kilometres from their camp (McConkey et al. 2012). They have been recorded travelling over 500 kilometres over 48 hours when moving from one camp to another (Roberts et al. 2012). GHFF generally show a high level of fidelity to camp sites, returning year after year to the same site, and have been recorded returning to the same branch of a particular tree (SEQ Catchments 2012). This may be one of the reasons flying-foxes continue to return to small urban bushland blocks that may be remnants of historically-used larger tracts of vegetation.

The GHFF population has a generally annual southerly movement in spring and summer, with their return to the coastal forests of north-east NSW and south-east Queensland in winter (Ratcliffe 1932; Eby 1991; Parry-Jones & Augee 1992; Roberts et al. 2012). This results in large fluctuations in the number of GHFF in NSW, ranging from as few as 20% of the total population in winter up to around 75% of the total population in summer (Eby 2000). They are widespread throughout their range during summer, but in spring and winter are uncommon in the south. In autumn they occupy primarily coastal lowland camps and are uncommon inland and on the south coast of NSW (DECCW 2009).

Stonequarry Creek Flying-fox Camp Management Plan

There is evidence the GHFF population declined by up to 30% between 1989 and 2000 (Birt 2000; Richards 2000 cited in OEH 2011a). There is a wide range of ongoing threats to the survival of the GHFF, including habitat loss and degradation, deliberate destruction associated with the commercial horticulture industry, conflict with humans, infrastructure-related mortality (e.g. entanglement in barbed wire fencing and fruit netting, power line electrocution, etc.) and competition and hybridisation with the BFF (DECCW 2009). For these reasons it is listed as vulnerable to extinction under NSW and federal legislation (see Section 4).

7. Human and animal health

Flying-foxes, like all animals, carry pathogens that may pose human health risks. Many of these are viruses which cause only asymptomatic infections in flying-foxes themselves but may cause significant disease in other animals that are exposed. In Australia the most well-defined of these include Australian bat lyssavirus (ABLV), Hendra virus (HeV) and Menangle virus. Specific information on these viruses is provided in Appendix 5.

Outside of an occupational cohort, including wildlife carers and vets, human exposure to these viruses is extremely rare and similarly transmission rates and incidence of human infection are very low. In addition, HeV infection in humans apparently requires transfer from an infected intermediate equine host and direct transmission from bats to humans has not been reported. Thus despite the fact that human infection with these agents can be fatal, the probability of infection is extremely low and the overall public health risk is judged to be low (Qld Health 2016).

7.1 Disease and flying-fox management

A recent study at several camps before, during and after disturbance (Edson et al. 2015) showed no statistical association between HeV prevalence and flying-fox disturbance. However the consequences of chronic or ongoing disturbance and harassment and its effect on HeV infection were not within the scope of the study and are therefore unknown.

The effects of stress are linked to increased susceptibility and expression of disease in both humans (AIHW 2012) and animals (Henry & Stephens-Larson 1985; Aich et. al. 2009), including reduced immunity to disease.

Therefore it can be assumed that management actions which may cause stress (e.g. dispersal), particularly over a prolonged period or at times where other stressors are increased (e.g. food shortages, habitat fragmentation, etc.), are likely to increase the susceptibility and prevalence of disease within the flying-fox population, and consequently the risk of transfer to humans.

Furthermore, management actions or natural environmental changes may increase disease risk by:

- forcing flying-foxes into closer proximity to one another, increasing the probability of disease transfer between individuals and within the population
- resulting in abortions and/or dropped young if inappropriate methods are used during critical periods of the breeding cycle. This will increase the likelihood of direct interaction between flying-foxes and the public, and potential for disease exposure
- adoption of inhumane methods with potential to cause injury which would increase the likelihood of the community coming into contact with injured/dying flying-foxes.

The potential to increase disease risk should be carefully considered as part of a full risk assessment when determining the appropriate level of management and the associated mitigation measures required.

8. Camp management options

8.1 Level 1 actions: routine camp management

8.1.1 Education and awareness programs

This management option involves undertaking a comprehensive and targeted flying-fox education and awareness program to provide accurate information to the local community about flying-foxes.

Such a program would include managing risk and alleviating concern about health and safety issues associated with flying-foxes, options available to reduce impacts from roosting and foraging flying-foxes, an up-to-date program of works being undertaken at the camp, and information about flying-fox numbers and flying-fox behaviour at the camp.

Residents should also be made aware that faecal drop and noise at night is mainly associated with plants that provide food, independent of camp location. Staged removal of foraging species such as fruit trees and palms from residential yards, or management of fruit (e.g. bagging, pruning) will greatly assist in mitigating this issue.

Collecting and providing information should always be the first response to community concerns in an attempt to alleviate issues without the need to actively manage flying-foxes or their habitat. Where it is determined that management is required, education should similarly be a key component of any approach. See also Section 3 and incorporate an education and awareness program into any community engagement plan.



Figure 5: Possible components of an education program

An education program may include components shown in Figure 5.

The likelihood of improving community understanding of flying-fox issues is high. However, the extent to which that understanding will help alleviate conflict issues is probably less so. Extensive education for decision-makers, the media and the broader community may be required to overcome negative attitudes towards flying-foxes.

It should be stressed that a long-term solution to the issue resides with better understanding flying-fox ecology and applying that understanding to careful urban planning and development.

8.1.2 Property modification without subsidies

The managers of land on which a flying-fox camp is located would promote or encourage the adoption of certain actions on properties adjacent or near to the camp to minimise impacts

from roosting and foraging flying-foxes (note that approval may be required for some activities, refer to Section 4 for further information):

- Create visual/sound/smell barriers with fencing or hedges. To avoid attracting flying-foxes, species selected for hedging should not produce edible fruit or nectar-exuding flowers, should grow in dense formation between two and five metres (Roberts 2006) (or be maintained at less than 5 metres). Vegetation that produces fragrant flowers can assist in masking camp odour where this is of concern.
- Manage foraging trees (i.e. plants that produce fruit/nectar-exuding flowers) within properties through pruning/covering with bags or [wildlife friendly netting](#), early removal of fruit, or tree replacement.
- Cover vehicles, structures and clothes lines where faecal contamination is an issue, or remove washing from the line before dawn/dusk.
- Move or cover eating areas (e.g. BBQs and tables) within close proximity to a camp or foraging tree to avoid contamination by flying-foxes.
- Install double-glazed windows, insulation and use air-conditioners when needed to reduce noise disturbance and smell associated with a nearby camp.
- Follow horse husbandry and property management guidelines provided at the NSW Department of Primary Industries [Hendra virus web page](#) (DPI 2015a).
- Include suitable buffers and other provisions (e.g. covered car parks) in planning of new developments.
- Turn off lighting at night which may assist flying-fox navigation and increase fly-over impacts.
- Consider removable covers for swimming pools and ensure working filter and regular chlorine treatment.
- Appropriately manage rainwater tanks, including installing first-flush systems.
- Avoid disturbing flying-foxes during the day as this will increase camp noise.

The cost would be borne by the person or organisation who modifies the property; however, opportunities for funding assistance (e.g. environment grants) may be available for management activities that reduce the need to actively manage a camp.

8.1.3 Property modification subsidies

Fully funding or providing subsidies to property owners for property modifications may be considered to manage the impacts of the flying-foxes. Providing subsidies to install infrastructure may improve the value of the property, which may also offset concerns regarding perceived or actual property value or rental return losses.

The level and type of subsidy would need to be agreed to by the entity responsible for managing the flying-fox camp.

8.1.4 Service subsidies

This management option involves providing property owners with a subsidy to help manage impacts on the property and lifestyle of residents. The types of services that could be subsidised include clothes washing, cleaning outside areas and property, car washing or power bills. Rate reductions could also be considered.

Critical thresholds of flying-fox numbers at a camp and distance to a camp may be used to determine when subsidies would apply.

8.1.5 Routine camp maintenance and operational activities

Examples of routine camp management actions are provided in the Policy. These include:

- removal of tree limbs or whole trees that pose a genuine health and safety risk, as determined by a qualified arborist

Stonequarry Creek Flying-fox Camp Management Plan

- weed removal, including removal of weeds declared as being of regional significance in the Greater Sydney Regional Strategic Weed Management Plan 2017 – 2022 in accordance with the *Biosecurity Act 2015*, or species listed as undesirable by a council
- trimming of understorey vegetation or the planting of vegetation
- minor habitat augmentation for the benefit of the roosting animals
- mowing of grass and similar grounds-keeping actions that will not create a major disturbance to roosting flying-foxes
- application of mulch or removal of leaf litter or other material on the ground.

Protocols should be developed for carrying out operations that may disturb flying-foxes, which can result in excess camp noise. Such protocols could include limiting the use of disturbing activities to certain days or certain times of day in the areas adjacent to the camp, and advising adjacent residents of activity days. Such activities could include lawn-mowing, using chainsaws, whipper-snippers, using generators and testing alarms or sirens.

8.1.6 Revegetation and land management to create alternative habitat

This management option involves revegetating and managing land to create alternative flying-fox roosting habitat through improving and extending existing low-conflict camps or developing new roosting habitat in areas away from human settlement.

Selecting new sites and attempting to attract flying-foxes to them has had limited success in the past, and ideally habitat at known camp sites would be dedicated as a flying-fox reserve. However, if a staged and long-term approach is used to make unsuitable current camps less attractive, whilst concurrently improving appropriate sites, it is a viable option (particularly for the transient and less selective LRFF). Supporting further research into flying-fox camp preferences may improve the potential to create new flying-fox habitat.

When improving a site for a designated flying-fox camp, preferred habitat characteristics detailed in Section 6.4 should be considered.

Foraging trees planted amongst and surrounding roost trees (excluding in/near horse paddocks) may help to attract flying-foxes to a desired site. They will also assist with reducing foraging impacts in residential areas. Consideration should be given to tree species that will provide year-round food, increasing the attractiveness of the designated site. Depending on the site, the potential negative impacts to a natural area will need to be considered if introducing non-indigenous plant species.

The presence of a water source is likely to increase the attractiveness of an alternative camp location. Supply of an artificial water source should be considered if unavailable naturally, however this may be cost-prohibitive.

Potential habitat mapping using camp preferences (see Section 6.4) and suitable land tenure can assist in initial alternative site selection. A feasibility study would then be required prior to site designation to assess likelihood of success and determine the warranted level of resource allocated to habitat improvement.

8.1.7 Provision of artificial roosting habitat

This management option involves constructing artificial structures to augment roosting habitat in current camp sites or to provide new roosting habitat. Trials using suspended ropes have been of limited success as flying-foxes only used the structures that were very close to the available natural roosting habitat. It is thought that the structure of the vegetation below and around the ropes is important.

8.1.8 Protocols to manage incidents

This management option involves implementing protocols for managing incidents or situations specific to particular camps. Such protocols may include 'bat watch' patrols at sites

that host vulnerable people, management of pets at sites popular for walking dogs or heat stress incidents (when the camp is subjected to extremely high temperatures leading to flying-foxes changing their behaviour and/or dying).

8.1.9 Participation in research

This management option involves participating in research to improve knowledge of flying-fox ecology to address the large gaps in our knowledge about flying-fox habits and behaviours and why they choose certain sites for roosting. Further research and knowledge sharing at local, regional and national levels will enhance our understanding and management of flying-fox camps.

8.1.10 Appropriate land-use planning

Land-use planning instruments may be able to be used to ensure adequate distances are maintained between future residential developments and existing or historical flying-fox camps. While this management option will not assist in the resolution of existing land-use conflict, it may prevent issues for future residents.

8.1.11 Property acquisition

Property acquisition may be considered if negative impacts cannot be sufficiently mitigated using other measures. This option will clearly be extremely expensive, however is likely to be more effective than dispersal and in the long-term may be less costly.

8.1.12 Do nothing

The management option to 'do nothing' involves not undertaking any management actions in relation to the flying-fox camp and leaving the situation and site in its current state.

8.2 Level 2 actions: in-situ management

8.2.1 Buffers

Buffers can be created through vegetation removal and/or the installation of permanent/semi-permanent deterrents.

Creating buffers may involve planting low-growing or spiky plants between residents or other conflict areas and the flying-fox camp. Such plantings can create a visual buffer between the camp and residences or make areas of the camp inaccessible to humans.

Buffers greater than 300 metres are likely to be required to fully mitigate amenity impacts (SEQ Catchments 2012). The usefulness of a buffer to mitigate odour and noise impacts generally declines if the camp is within 50 metres of human habitation (SEQ Catchments 2012), however any buffer will assist and should be as wide as the site allows.

Buffers through vegetation removal

Vegetation removal aims to alter the area of the buffer habitat sufficiently so that it is no longer suitable as a camp. The amount required to be removed varies between sites and camps, ranging from some weed removal to removal of most of the canopy vegetation.

Any vegetation removal should be done using a staged approach, with the aim of removing as little native vegetation as possible. This is of particular importance at sites with other values (e.g. ecological or amenity), and in some instances the removal of any native vegetation will not be appropriate. Thorough site assessment (further to desktop searches, see Appendix 3 and 4) will inform whether vegetation management is suitable (e.g. can impacts to other wildlife and/or the community be avoided?).

Removing vegetation can also increase visibility into the camp and noise issues for neighbouring residents which may create further conflict.

Suitable experts (Appendix 6) should be consulted to assist selective vegetation trimming/removal to minimise vegetation loss and associated impacts.

The importance of under- and mid-storey vegetation in the buffer area for flying-foxes during heat stress events also requires consideration.

Buffers without vegetation removal

Permanent or semi-permanent deterrents can be used to make buffer areas unattractive to flying-foxes for roosting, without the need for vegetation removal. This is often an attractive option where vegetation has high ecological or amenity value.

While many deterrents have been trialled in the past with limited success, there are some options worthy of further investigation:

- Visual deterrents – Visual deterrents such as plastic bags, fluoro vests (GeoLINK 2012) and balloons (Ecosure 2016, pers. comm.) in roost trees have shown to have localised effects, with flying-foxes deterred from roosting within 1–10 metres of the deterrents. The type and placement of visual deterrents would need to be varied regularly to avoid habituation.
- Noise emitters on timers – Noise needs to be random, varied and unexpected to avoid flying-foxes habituating. As such these emitters would need to be portable, on varying timers and a diverse array of noises would be required. It is likely to require some level of additional disturbance to maintain its effectiveness, and ways to avoid disturbing flying-foxes from desirable areas would need to be identified. This is also likely to be disruptive to nearby residents.
- Smell deterrents – For example, bagged python excrement hung in trees has previously had a localised effect (GeoLINK 2012). The smell of certain deterrents may also impact nearby residents, and there is potential for flying-foxes to habituate.
- Canopy-mounted water sprinklers – This method has been effective in deterring flying-foxes during dispersals (Ecosure personal experience), and a current trial in Queensland is showing promise for keeping flying-foxes out of designated buffer zones. This option can be logistically difficult (installation and water sourcing) and may be cost-prohibitive. Design and use of sprinklers need to be considerate of animal welfare and features of the site. For example, misting may increase humidity and exacerbate heat stress events, and overuse may impact other environmental values of the site.

Note that any deterrent with a high risk of causing inadvertent dispersal may be considered a Level 3 action.

The use of visual deterrents, in the absence of effective maintenance, could potentially lead to an increase in rubbish in the natural environment.

8.2.2 Noise attenuation fencing

Noise attenuation fencing could be installed in areas where the camp is particularly close to residents. This may also assist with odour reduction, and perspex fencing could be investigated to assist fence amenity. Although expensive to install, this option could negate the need for habitat modification, maintaining the ecological values of the site, and may be more cost-effective than ongoing management.

8.3 Level 3 actions: disturbance or dispersal

8.3.1 Nudging

Noise and other low intensity active disturbance restricted to certain areas of the camp can be used to encourage flying-foxes away from high conflict areas. This technique aims to actively 'nudge' flying-foxes from one area to another, while allowing them to remain at the camp site.

Unless the area of the camp is very large, nudging should not be done early in the morning as this may lead to inadvertent dispersal of flying-foxes from the entire camp site. Disturbance during the day should be limited in frequency and duration (e.g. up to four times per day for up to 10 minutes each) to avoid welfare impacts. As with dispersal, it is also critical to avoid periods when dependent young are present (as identified by a flying-fox expert).

8.3.2 Dispersal

Dispersal aims to encourage a camp to move to another location, through either disturbance or habitat modification.

There is a range of potential risks, costs and legal implications that are greatly increased with dispersal (compared with in-situ management as above). See Appendix 7 for more details. These include:

- impact on animal welfare and flying-fox conservation
- splintering the camp into other locations that are equally or more problematic
- shifting the issue to another area
- impact on habitat value
- effects on the flying-fox population, including disease status and associated public health risk
- impacts to nearby residents associated with ongoing dispersal attempts
- excessive initial and/or ongoing capacity and financial investment
- negative public perception and backlash
- increased aircraft strike risk associated with changed flying-fox movement patterns
- unsuccessful management requiring multiple attempts, which may exacerbate all of the above.

Despite these risks, there are some situations where camp dispersal may be considered. Dispersal can broadly be categorised as 'passive' or 'active' as detailed below.

Passive dispersal

Removing vegetation in a staged manner can be used to passively disperse a camp, by gradually making the habitat unattractive so that flying-foxes will disperse of their own accord over time with little stress (rather than being more forcefully moved with noise, smoke, etc.). This is less stressful to flying-foxes, and greatly reduces the risk of splinter colonies forming in other locations (as flying-foxes are more likely to move to other known sites within their camp network when not being forced to move immediately, as in active dispersal).

Generally, a significant proportion of vegetation needs to be removed in order to achieve dispersal of flying-foxes from a camp or to prevent camp re-establishment. For example, flying-foxes abandoned a camp in Bundall, Queensland once 70% of the canopy/mid-storey and 90% of the understorey had been removed (Ecosure 2011). Ongoing maintenance of the site is required to prevent vegetation structure returning to levels favourable for colonisation by flying-foxes. Importantly, at nationally important camps sufficient vegetation must be retained to accommodate the maximum number of flying-foxes recorded at the site.

This option may be preferable in situations where the vegetation is of relatively low ecological and amenity value, and alternative known permanent camps are located nearby with capacity to absorb the additional flying-foxes. While the likelihood of splinter colonies forming is lower than with active dispersal, if they do form following vegetation modification there will no longer be an option to encourage flying-foxes back to the original site. This must be carefully considered before modifying habitat.

There is also potential to make a camp site unattractive by removing access to water sources. However at the time of writing this method had not been trialled so the likelihood of this causing a camp to be abandoned is unknown. It would also likely only be effective where there are no alternative water sources in the vicinity of the camp.

Active dispersal through disturbance

Dispersal is more effective when a wide range of tools are used on a randomised schedule with animals less likely to habituate (Ecosure pers. obs. 1997–2015). Each dispersal team member should have at least one visual and one aural tool that can be used at different locations on different days (and preferably swapped regularly for alternate tools). Exact location of these and positioning of personnel will need to be determined on a daily basis in response to flying-fox movement and behaviour, as well as prevailing weather conditions (e.g. wind direction for smoke drums).

Active dispersal will be disruptive for nearby residents given the timing and nature of activities, and this needs to be considered during planning and community consultation.

This method does not explicitly use habitat modification as a means to disperse the camp, however if dispersal is successful, some level of habitat modification should be considered. This will reduce the likelihood of flying-foxes attempting to re-establish the camp and the need for follow-up dispersal as a result. Ecological and aesthetic values will need to be considered for the site, with options for modifying habitat the same as those detailed for buffers above.

Early dispersal before a camp is established at a new location

This management option involves monitoring local vegetation for signs of flying-foxes roosting in the daylight hours and then undertaking active or passive dispersal options to discourage the animals from establishing a new camp. Even though there may only be a few animals initially using the site, this option is still treated as a dispersal activity, however it may be simpler to achieve dispersal at these new sites than it would in an established camp. It may also avoid considerable issues and management effort required should the camp be allowed to establish in an inappropriate location.

It is important that flying-foxes feeding overnight in vegetation are not mistaken for animals establishing a camp.

Maintenance dispersal

Maintenance dispersal refers to active disturbance following a successful dispersal to prevent the camp from re-establishing. It differs from initial dispersal by aiming to discourage occasional over-flying individuals from returning, rather than attempting to actively disperse animals that have been recently roosting at the site. As such, maintenance dispersal may have fewer timing restrictions than initial dispersal, provided that appropriate mitigation measures are in place (see Section 10).

8.4 Unlawful activities

8.4.1 Culling

Culling is addressed here as it is often raised by community members as a preferred management method; however, culling is contrary to the objects of the TSC Act and will not be permitted as a method to manage flying-fox camps.

Stonequarry Creek Flying-fox Camp Management Plan

Management options	Relevant impacts	Cost \$-\$\$\$ Low-high	Advantages	Disadvantages	Suitability for the site
rebates (Section 8.14)	Faecal drop Health/wellbeing Property devaluation Lost rental return		would reduce the need for property modification.	unrealistic community expectations for other community issues, effort required to determine who would receive subsidies.	Appraisal: Investigate further
Routine camp management (Section 8.1.5)	Health/wellbeing	\$	Will allow property maintenance, likely to improve habitat, could improve public perception of the site, will ensure safety risks of a public site can be managed. Weed removal has the potential to reduce roost availability and reduce numbers of roosting flying-foxes. To avoid this, weed removal should be staged and alternative roost habitat planted, otherwise activities may constitute a Level 3 action. Follow-up privet control is required to prevent it re-establishing within the created buffer areas.	Will not generally mitigate amenity impacts for nearby landholders.	The majority, 66%, of the Stonequarry Creek camp occurs on private property and the rest on Crown Reserve, and much of the habitat is comprised of weed species (e.g. privet). General maintenance of properties that are not intended to disturb the camp, such as mowing, can be done by residents without a licence. However, weed removal within the known camp extent (other than habitat restoration) should not be undertaken without OEH approval. Protocols should be developed for some activities (see below). Appraisal: Adopt
Alternative habitat creation (Section 8.1.6)	Noise Smell Faecal drop Health/wellbeing Property devaluation Lost rental return	\$\$-\$\$\$	If successful in attracting flying-foxes away from high conflict areas, dedicated habitat in low conflict areas will mitigate all impacts and helps flying-fox conservation. Rehabilitation of degraded habitat that is likely to be suitable for flying-fox use could be a more practical and faster approach than habitat creation. Improving potential alternative camp habitat on the island could be part of a medium-long term plan.	Generally costly, long-term approach so cannot be undertaken quickly, previous attempts to attract flying-foxes to a new site have not been known to succeed.	There is a large amount of similar habitat considered suitable for roosting flying-foxes along Stonequarry Creek. The majority of this habitat is privately owned and also surrounded by residences. As such if the camp was at most alternative locations in the surrounds it would cause similar levels of conflict. The extensive availability of suitable alternative habitat would almost certainly result in any attempts to create habitat elsewhere unsuccessful. Similarly any disturbance at the current camp would most likely result in them establishing at an equally problematic location. Appraisal: Not currently feasible The Stonequarry Creek Landcare Group is already working in areas of the site, and there may be potential for them to include in-situ

Stonequarry Creek Flying-fox Camp Management Plan

Management options	Relevant impacts	Cost \$-\$\$\$ Low-high	Advantages	Disadvantages	Suitability for the site
					flying-fox habitat management in their scope of works. Appraisal: Adopt
Provision of artificial roosting habitat (Section 8.1.7)	Noise Smell Faecal drop Health/wellbeing Property devaluation Lost rental return	\$-\$\$	If successful in attracting flying-foxes away from high conflict areas, dedicated habitat in low conflict areas will mitigate all impacts, promotes flying-fox conservation.	Generally costly, previous attempts to attract flying-foxes to a new site have not been known to succeed.	Artificial roosting habitat is still in its trial stages. Trials are not considered a priority at this site as while vegetation on site is affected by flying-foxes, it is primarily weedy and the site can be managed without provision of additional roost space. Appraisal: Disregard
Protocols to manage incidents (Section 8.1.8)	Health/wellbeing Fear of disease	\$	Low cost, will reduce actual risk of negative human/pet–flying-fox interactions, promotes conservation of flying-foxes, can be undertaken quickly, will not impact the site. Protocols should be developed for staff and volunteers working in the creek-line and health information included on interpretative signage.	Will not mitigate amenity impacts, but will reduce fear of disease.	Council should develop safe work methods for staff working along the creek-line and under the camp. Council could share this with contractors and Landcare groups to ensure they are aware of appropriate risk management and their responsibilities under the Policy. Appraisal: Adopt
Research (Section 8.1.9)	Noise Smell Faecal drop Health/wellbeing Property devaluation Lost rental return	\$	Supporting research to improve understanding may contribute to more effectively mitigating all impacts, promotes flying-fox conservation.	Generally cannot be undertaken quickly, management trials may require cost input.	Not considered an urgent action at this site. Council will endeavour to stay up to date with contemporary research as it arises. Appraisal: Adopt (low priority)
Appropriate land-use planning (Section 8.1.10)	Noise Smell Faecal drop Health/wellbeing Property devaluation Lost rental	\$	Suitable planning for future development will reduce potential for future conflict. Identification of degraded sites that may be suitable for long-term rehabilitation for flying-foxes could reduce impacts.	Will not generally mitigate current impacts, land-use restrictions may impact the landholder.	Council may consider including additional management buffer zones within their codes in future local environment plan updates if appropriate. Appraisal: Investigate further

Stonequarry Creek Flying-fox Camp Management Plan

Management options	Relevant impacts	Cost \$-\$\$\$ Low-high	Advantages	Disadvantages	Suitability for the site
	return				
Property acquisition (Section 8.1.11)	All for specific property owners Nil for broader community	\$\$\$	Will reduce future conflict with the owners of acquired property.	Owners may not want to move, only improves amenity for those who fit criteria for acquisition, very expensive.	This option is cost prohibitive with the number of properties surrounding the camp. Appraisal: Not feasible
Do nothing (Section 8.1.12)	Nil	Nil	No resource expenditure.	Will not mitigate impacts and would not be considered acceptable by impacted members of the community.	Not appropriate for this site. Appraisal: Disregard
Level 2 actions					
Buffers through vegetation removal (Section 8.2.1)	Noise Smell Health/wellbeing	\$-\$\$	Any vegetation removal should be done using a staged approach, with the aim of removing as little native vegetation as possible and only in vegetation directly behind affected residents.	Removing vegetation can also increase visibility into the camp and noise issues for neighbouring residents which may create further conflict.	Clearing of native vegetation can be permitted within the TEC if approved by OEH. Buffers of less attractive habitat may be created by removing weeds, which may be suitable for properties that border the camp along Lumsdaine and Campbell Street. OEH approval required for weed removal in the camp area Appraisal: Adopt (high priority)
Buffers without vegetation removal – visual deterrents, canopy mounted sprinklers (Section 8.2.1)	Noise Smell Health/wellbeing Damage to vegetation	\$\$	Canopy-mounted water sprinklers – This method has been effective in deterring flying-foxes from designated buffer zones in Queensland (Ecosure pers comm.). Visual deterrents – Visual deterrents such as plastic bags, fluoro vests (GeoLINK 2012) and balloons (Ecosure 2016, pers. comm.) in roost trees have shown to have localised effects, with flying-foxes deterred from roosting within 1–10 metres of the deterrents.	This option can be logistically difficult (installation and water sourcing) and may be cost-prohibitive. Misting may increase humidity and exacerbate heat stress events, and overuse may impact other environmental values of the site. The type and placement of visual deterrents would need to be varied regularly to avoid habituation. Potentially lead to increase in rubbish in the natural environment.	While canopy sprinklers may be suitable for use in a desired buffer zone, it would be cost prohibitive for private landholders to install and maintain and has not been considered further at this stage. Appraisal: Investigate further
Noise attenuation fencing	Noise Smell	\$\$	Will eliminate/significantly reduce noise from the camp, will reduce other impacts, limited	Noise attenuation fencing is costly. There are cheaper	Due to the slope of the site the flying-foxes roost is significantly lower than the residential

Stonequarry Creek Flying-fox Camp Management Plan

Management options	Relevant impacts	Cost \$-\$\$\$ Low-high	Advantages	Disadvantages	Suitability for the site
(Section 8.2.2)	Health/wellbeing Property devaluation Lost rental return/income		maintenance costs.	alternatives which can be attached to existing fencing.	lots. Noise typically travels up easily and with limited reduction in volume because there are no barriers around which to refract. Top significantly reduce volume, noise needs to be made to travel a longer distance or refract around a barrier. Fencing would, therefore, need to be above the height of the roosting GHFF. As a result, it would either need to be near the residences (unlikely to be agreeable to landholders or very high which would take away from the panoramic views of the area). Appraisal: Disregard
Level 3 actions					
Nudging (Section 8.3.1)	All	\$\$-\$\$\$	Can encourage flying-foxes to shift away from high conflict areas next to residential areas.	May lead to inadvertent dispersal if not done at the correct time, frequency or duration.	As detailed above, there is no suitable alternative in the surrounds where the camp could be nudged to. Appraisal: Disregard
Dispersal (Section 8.3.2)	All at that site but not generally appropriate for amenity impacts only (see Section 8)	\$\$\$	If successful can mitigate all impacts at that site.	As detailed in Section 8.3.2, dispersal is rarely successful without significant vegetation removal (not appropriate at this location) or ongoing effort and excessive expenditure (e.g. several years and \$1M for Sydney Botanic Gardens). Flying-foxes will almost always continue to roost in the area (generally within 600m), and often splinter into several locations nearby (including many remaining at the original site) (e.g. a single camp permanently splintered to numerous sites as a result of dispersal in Maclean, including remaining at the original site).	As detailed above, the camp could possibly establish in an undesirable alternative location, which would cause similar levels of conflict. The site is also very steep and would not be safe to access at night for active dispersal. Appraisal: Not feasible

9. Planned management approach

Table 4 outlines actions planned over the five-year life of this Plan. These actions are based on community feedback during consultation, and site-specific analysis of available management options (Section 8.5).

As detailed in Section 2.2, the camp is located on non-Council property (private and Crown). As such, Council is unable to take an active role in on-ground works, however will support the community wherever possible.

Any on-ground works must be in compliance with stop work triggers in Section 9.1 and measures to avoid impacts in Section 10.

Table 4 Management approach overview

Management aim and success measure	Actions	Action level under the Policy (see Sections 4 and 8)	Licence application required (see Section 4)
<p>Aim: Assist reducing amenity impacts (e.g. noise, faecal drop, etc) for the community adjacent the camp.</p> <p>Measure: A reasonable level of amenity maintained for surrounding community.</p>	<p>Continue to develop and implement education strategies ensuring affected landholders are aware of:</p> <ul style="list-style-type: none"> measures available to reduce amenity impacts, including options for noise attenuation fencing (see Sections 8.1 and 8.2.2) appropriate replacements for foraging trees which will assist with night time noise and faecal drop appropriate general hygiene measures for rain water tanks (e.g. first flush systems) what to do if a dead, injured or orphaned flying-fox is found, including relevant contact details. 	L1	N/A
	<p>Investigate a community subsidies program (see Table 3). Such a program, if feasible, should be scaled with proximity to the camp (up to 300 m). An ongoing subsidies program may also be scaled with numbers at the camp and camp extent so that the level of assistance reflects impacts.</p>	L1	N/A
	<p>Consult with odour management specialists (e.g. Odour Pro www.odours.com.au) to determine the feasibility and likely benefits of an odour neutralising system (see Appendix 8, retailing between \$5,500 and \$7,500 for up to 150 m). Such a system should not be used in the camp to avoid negatively impacting flying-foxes, but may be useful closer to residences.</p>	L1	✓
	<p>Consult with the community regarding support for buffer zones (as shown on Map 4 and outlined in Section 10.2), which would be at individual landholder expense (subsidies may apply). Proposed buffer zones provide a minimum 10 m additional buffer from residences, up to 20 m where habitat is available and bank stability can be maintained. If of interest, Council will apply to OEH for a combined licence and oversee management to ensure compliance with legislation, licence conditions, and this Plan. If buffers are to progress, they should be included in a detailed plan (see below restoration plan action)</p> <p>Council will also investigate the option of providing residents with TEC-appropriate plants from the Council nursery to replace weeds removed from the buffer zone.</p> <p>N.B. Buffer areas shown in Map 4 are indicative only. Buffers may need to be reduced in areas to ensure bank stability. Similarly, complex vegetation structure is key in protecting flying-foxes during extreme weather (e.g. extreme temperatures in January 2018, where flying-fox mortality was high in surrounding areas but no mortality</p>	L2	✓

Stonequarry Creek Flying-fox Camp Management Plan

Management aim and success measure	Actions	Action level under the Policy (see Sections 4 and 8)	Licence application required (see Section 4)
	was recorded at the Picton camp). Buffer works should not increase the susceptibility of flying-foxes to heat-related mortality at the site. Flying-fox behaviour and site use during hot days should be monitored by a flying-fox expert before confirming buffer areas in the weed removal/restoration plan (see action below).		
	Keep abreast of new research outcomes which may inform future impact mitigation measures, particularly the ability to 'attract' flying-foxes to low conflict locations or other ways to better mitigate community impacts.	L1	N/A
<p>Aim: Ensure risks are appropriately managed.</p> <p>Measure: Risk mitigation information readily available to the community.</p>	Develop and conduct relevant training for all staff/community involved in any flying-fox management action and those who will be dealing with complaints/inquiries.	L1	N/A
	Ensure appropriate risk mitigation strategies are communicated to the community adjacent the camp (see first action above), and are readily available to the shire-wide community.	L1	N/A
	Develop safe work methods for staff working under and around the camp, and provide to relevant groups and contractors.	L1	N/A
	Develop a heat stress event protocol detailing Council's role in managing such incidents, and planning the response to flying-fox mortality.	L1	N/A
	Arrange and fund collection of flying-foxes from private property during mass mortality events (if required).	L1	N/A
<p>Aim: Protect the TEC and camp habitat within low conflict locations</p> <p>Measure: Stonequarry Creek camp restoration plan developed and being implemented</p>	In consultation with the Stonequarry Creek Landcare Group, a flying-fox expert, and relevant land managers of Crown land, develop a weed removal and restoration plan prior to any works additional to those currently being undertaken by the Landcare Group. The plan should focus on improving habitat on Crown land in identified lower conflict areas as well as conserving the TEC, and must be considerate of flying-fox (and other fauna) habitat requirements and welfare (e.g. including requirements during extreme weather, see detail in buffer action above).	L1	N/A
<p>Aim: Assist impacts on primary producers in the community.</p>	Engage with orchardists so they are aware of the significant foraging distances flying-foxes travel each night (i.e. attempting to disperse the camp would not reduce foraging impacts).	L1	N/A
	Investigate potential sources of funding assistance which may be available to landholders through grant schemes and low-interest loans (e.g. farm innovation fund to assist primary producers), and communicate to relevant landholders.	L1	N/A
	Include, where appropriate (e.g. in low conflict locations), flying-fox foraging species when revegetating Council-owned open space, which will help reduce foraging pressure on orchards. There is a particular need to increase the availability of winter-flowering and fruiting foraging species (see Eby 2016 and Eby 1995 for further information).	L1	N/A

Stonequarry Creek Flying-fox Camp Management Plan

Map 4 Potential management areas



Map 4: Potential management areas

Wollondilly Shire Council
Stonequarry Creek Camp Management Plan

- Approximate camp extent July 2017
- Potential buffer area (weed removal only)
- Additional area for improvement (Crown Land)
- Current restoration area (Crown Land)
- Maximum known extent January 2018



Job number: PR1276
Revision: 0
Author: AJM
Date: 16/01/2014



GDA 1984 MGA Zone 58
Project: Transverse Mapper
Datum: GDA 1984
Units: Meter

©2014 Ecosure Services Pty Ltd. All Rights Reserved. Ecosure is a registered trademark of Ecosure Services Pty Ltd. All other trademarks are the property of their respective owners. This map and any content being displayed on this web site, is the property of Ecosure Services Pty Ltd. All other trademarks are the property of their respective owners.

9.1 Stop work triggers

Stop work triggers will be confirmed in licence conditions or will be required to be as per a code of practise (should a code be made under the BC Act and be applicable to this camp).

Any management will cease and will not recommence or progress to subsequent levels without consulting OEH if:

- any of the animal welfare triggers occur on more than two days during the program, such as unacceptable levels of stress (see Table 5)
- there is a flying-fox injury or death
- a new camp/camps appear to be establishing
- impacts are created or exacerbated at other locations
- there appears to be potential for conservation impacts
- standard measures to avoid impacts (detailed in Section 10.4) cannot be met.

Management may also be terminated at any time if:

- unintended impacts are created for the community around the camp
- allocated resources are exhausted.

Table 5: Planned action for potential impacts during management. A person with experience in flying-fox behaviour (as per Appendix 6) will monitor for welfare triggers and direct works in accordance with the criteria below

Welfare trigger	Signs	Action
Unacceptable levels of stress	If any individual is observed: <ul style="list-style-type: none"> • panting • saliva spreading • located on or within 2 m of the ground 	Works to cease for the day.
Fatigue	In-situ management <ul style="list-style-type: none"> • more than 30% of the camp takes flight • individuals are in flight for more than 5 minutes • flying-foxes appear to be leaving the camp Dispersal <ul style="list-style-type: none"> • low flying • laboured flight • settling despite dispersal efforts 	In-situ management Works to cease and recommence only when flying-foxes have settled* / move to alternative locations at least 50 m from roosting animals. Dispersal Works to cease for the day.

Stonequarry Creek Flying-fox Camp Management Plan

Welfare trigger	Signs	Action
Injury/death	<ul style="list-style-type: none"> • a flying-fox appears to have been injured/killed on site (including aborted foetuses) • any flying-fox death is reported within 1 km of the dispersal site that appears to be related to the dispersal • females in final trimester • dependent/crèching young present • loss of condition evident 	<p>Works to cease immediately and OEH notified</p> <p>AND</p> <p>rescheduled</p> <p>OR</p> <p>adapted sufficiently so that significant impacts (e.g. death/injury) are highly unlikely to occur, as confirmed by an independent expert (see Appendix 6)</p> <p>OR</p> <p>stopped indefinitely and alternative management options investigated.</p>

*maximum of two unsuccessful attempts to recommence work before ceasing for the day.

10. Assessment of impacts

Measures to avoid impacts during Plan implementation are provided in Section 10.4.

10.1 Regional context

Proposed Level 2 actions do not aim to disperse any individuals from the site and so potential habitat has not been modelled. There are only three known camp sites within 25 km (Table 6), with the closest being Menangle 13 km away. As this is a significant distance, and there are no camps within 25 km to the south, it is probable that any significant disturbance would result in the formation of a new camp in the local area. Actions in this Plan will ensure disturbance at the Stonequarry Creek camp are minimised, which will in turn minimise the:

- likelihood of splinter camps forming in undesirable locations within Wollondilly Shire
- potential to influence conflict around camps in the region.

Table 6 Known camps within 25km

Proximity and direction compared to Stonequarry camp	Camp name , suburb	Anticipated potential for conflict
13 km ENE	Menangle, Menangle	Low-moderate (previous health impacts with Menangle virus – see Appendix 5)
22 km NE	Campbelltown, Campbelltown	High (close proximity to residents)
17 km N	Camden, Brownlow Hill	Low

10.2 Flying-fox habitat to be affected

The potential buffer area includes 0.46 ha of the 3.31 ha known maximum camp area (Map 4). This buffer area assumes all residents will undertake weed removal on their own lots, which is highly unlikely. It is anticipated to be less than half this area (i.e. <0.2 ha). It is planned that the buffer will be made less attractive to roosting flying-foxes by gradually removing weeds (i.e. no native vegetation removal). From the edge of the bank, weeds will be replaced with low-growing native species (shrubs and ground-covers) suited to the TEC to ensure bank stability.

The flying-fox expert assessment as part of this Plan development suggests that creating a buffer will retain sufficient habitat for the peak number of flying-foxes. However, should additional roost space be needed to accommodate occasional influxes in the interim while remaining habitat is being improved through habitat restoration and natural regeneration, there is suitable habitat available south of Victoria Bridge. Given the height of Victoria Bridge the camp would remain visually connected, as generally preferred.

Ongoing restoration by the Stonequarry Creek Landcare Group will facilitate continual native canopy gain. Additional areas have also been identified for improvement to offset any remaining loss of camp habitat associated with weed removal. It is critical that all weed removal and restoration works are considerate of flying-fox habitat requirements, particularly

maintaining sufficient mid-storey for protection in extreme weather (e.g. heat stress events). Retaining a complex structure is also important for other native fauna known to occur on site (e.g. fairy-wrens and finches, see Section 5). Initial works in identified improvement areas should be gap planting only to provide additional habitat. Weeds, particularly privet which is favoured by flying-foxes, should remain undisturbed in these improvement areas while gap plantings establish. This will avoid sudden change to vegetation structure and composition which may make the habitat unsuitable. As gap plantings establish, weedy mid-storey should be removed gradually in a mosaic pattern to allow natural regeneration. As per Table 4 a vegetation management plan will be developed for the site with input from a flying-fox expert.

Weed removal will result in a net biodiversity gain, and protect the long-term sustainability of the TEC with native species able to regenerate following weed removal.

10.3 Assessment of impacts to other threatened species or communities

As per Section 5 and Appendix 3, 40 threatened species and one TEC were assessed for their likelihood of occurrence (based on Bionet search results). Nine flora and 15 fauna species could possibly occur at the site (Appendix 3), and the TEC was confirmed.

The approach advocated for in this Plan consists entirely of weed removal, assisted regeneration and replanting native species suited to the TEC. A detailed restoration plan will ensure sufficient vegetation structure is retained at all times during restoration works to avoid impacting any fauna. As such it is anticipated there will be net benefits to the TEC and threatened species that may occur on site, and further assessment (such as an assessment of significance under the *Biodiversity Conservation Act 2016*, or Significant Impact Guidelines 1.1 – Matters of National Environmental Significance under the EPBC Act) is not considered necessary.

10.4 Measures to avoid impacts

The following mitigation measures will be complied with at all times during Plan implementation. The measures to avoid impacts will be confirmed in licence conditions or will be required as per the code of practise (should a code be made under the BC Act and be applicable to this camp).

10.4.1 All management activities

- All personnel will be appropriately experienced, trained and inducted. Induction will include each person's responsibilities under this Plan.
- All personnel will be briefed prior to the action commencing each day, and debriefed at the end of the day.
- Works will cease and OEHL consulted in accordance with the following 'stop work triggers' section of the Plan.
- Large crews will be avoided where possible.
- The use of loud machinery and equipment that produces sudden impacts/noise will be limited. Where loud equipment (e.g. chainsaws) is required they will be started away from the camp and allowed to run for a short time to allow flying-foxes to adjust.

Stonequarry Creek Flying-fox Camp Management Plan

- Activities that may disturb flying-foxes at any time during the year will begin as far from the camp as possible, working towards the camp gradually to allow flying-foxes to habituate.
- Non-critical activities will ideally be scheduled when the camp is naturally empty. Where this is not possible they will be scheduled for the best period for that camp (e.g. when the camp is seasonally lower in numbers and breeding will not be interrupted, or during the non-breeding season, generally May to July).
- Any activity likely to disturb flying-foxes so that they take flight will be avoided during the day during the sensitive GHFF/BFF birthing period (i.e. when females are in final trimester or the majority are carrying pups, generally August – December) and avoided altogether during crèching (generally November/December – February). If required during these periods a person experienced in flying-fox behaviour will monitor the camp for at least the first two scheduled actions (or as otherwise deemed to be required by that person) to ensure impacts are not excessive and advise on the most appropriate methods (e.g. required buffer distances, approach, etc.).
- OEH will be immediately contacted if LRFF are present between March and October, or are identified as being in final trimester / with dependent young.
- Works will not take place in periods of adverse weather including strong winds, sustained heavy rains, in very cold temperatures or during periods of likely population stress (e.g. food bottlenecks). Wildlife carers will be consulted to determine whether the population appears to be under stress.
- Works will be postponed on days predicted to exceed 35°C (or ideally 30°C), and for one day following a day that reached $\geq 35^{\circ}\text{C}$. If an actual heat stress event has been recorded at the camp or at nearby camps, a rest period of several weeks will be scheduled to allow affected flying-foxes to fully recover. See the OEH fact sheet on [Responding to heat stress in flying-fox camps](#).
- If impacts at other sites are considered, in OEH's opinion, to be a result of management actions under this Plan, assistance will be provided to the relevant land manager to ameliorate impacts. Details of this assistance are to be developed in consultation with OEH.
- Any proposed variations to works detailed in the Plan will be approved, in writing, by OEH before any new works occur.
- OEH may require changes to methods or cessation of management activities at any time.
- Ensure management actions and results are recorded to inform future planning. See the OEH fact sheet on [Monitoring, evaluating and reporting](#).

10.4.2 All Level 2 actions

Prior to works

- Residents adjacent to the camp will be individually notified one week prior to on-ground works commencing. This will include information on what to do if an injured or orphaned flying-fox is observed, a reminder not to participate in or interfere with the program, and details on how to report unusual flying-fox behaviour/daytime sightings. Relevant contact details will be provided (e.g. Program Coordinator). Resident requests for retention of vegetation and other concerns relating to the program will be taken into consideration.
- Where the Plan is being implemented by Council, information will be placed on Council's website along with contact information.
- OEH will be notified at least 48 hours before works commence.
- A protocol, in accordance with the [NSW Code of Practice for Injured, Sick and Orphaned Flying-foxes](#) (OEH 2012), for flying-fox rescue will be developed including contact details of rescue and rehabilitation organisations. This protocol will be made available to all

Stonequarry Creek Flying-fox Camp Management Plan

relevant staff, residents and volunteers prior to the action commencing. See Appendix 9 for an example protocol.

- A licensed wildlife carer will be notified prior to beginning works in the event that rescue/care is required.

Monitoring

- A flying-fox expert (identified in section 12.3) will undertake an on-site population assessment prior to, during works and after works have been completed, including:
 - number of each species
 - ratio of females in final trimester
 - approximate age of any pups present including whether they are attached or likely to be crèched
 - visual health assessment
 - mortalities.
- Counts will be done at least:
 - once immediately prior to works
 - daily during works
 - immediately following completion
 - one month following completion
 - 12 months following completion.

During works

- A flying-fox expert will attend the site as often as OEH considers necessary to monitor flying-fox behaviour and ensure compliance with the Plan and the Policy. They must also be able to identify pregnant females, flightless young, individuals in poor health and be aware of climatic extremes and food stress events. This person will make an assessment of the relevant conditions and advise the supervisor/proponent whether the activity can go ahead.
- At least one flying-fox rest day with no active management will be scheduled fortnightly, preferably weekly.

10.4.3 Vegetation trimming/removal

- Dead wood and hollows will be retained on site where possible as habitat.
- Vegetation chipping is to be undertaken as far away from roosting flying-foxes as possible.
- No tree in which a flying-fox is roosting will be trimmed or removed. Works may continue in trees adjacent to roost trees only where a person experienced in flying-fox behaviour assesses that no flying-foxes are at risk of being harmed. A person experienced in flying-fox behaviour is to remain on site to monitor, when canopy trimming/removal is required within 50 metres of roosting flying-foxes.

Human safety

- All personnel to wear protective clothing including long sleeves and pants; additional items such as eye protection and a hat are also recommended. People working under the camp should wash their clothes daily. Appropriate hygiene practices will be adopted such as washing hands with soap and water before eating/smoking.
- All personnel who may come into contact with flying-foxes will be vaccinated against Australian bat lyssavirus with current titre.
- A wash station will be available on site during works along with an anti-viral antiseptic (e.g. Betadine) should someone be bitten or scratched.

Stonequarry Creek Flying-fox Camp Management Plan

- Details of the nearest hospital or doctor who can provide post-exposure prophylaxis will be kept on site.

10.4.4 Bush regeneration

- All works will be carried out by suitably qualified and experienced bush regenerators, with at least one supervisor knowledgeable about flying-fox habitat requirements (and how to retain them for Level 1 and 2 actions) and trained in working under a camp.
- Vegetation modification, including weed removal, will not alter the conditions of the site such that it becomes unsuitable flying-fox habitat for Level 1 and 2 actions.
- Weed removal should follow a mosaic pattern, maintaining refuges in the mid- and lower storeys at all times.
- Weed control in the core habitat area will be undertaken using hand tools only (or in the evening after fly-out while crèching young are not present).
- Species selected for revegetation will be consistent with the habitat on site, and in buffer areas or conflict areas should be restricted to small shrubs/understorey species to reduce the need for further roost tree management in the future.

11. Reporting on the implementation of the Plan

Reporting requirements will be confirmed in licence conditions or will be required as per the code of practise (should a code be made under the BC Act and be applicable to this camp).

- Each report is to include:
 - results of pre- and post-work population monitoring
 - any information on new camps that have formed in the area
 - impacts at other locations that may have resulted from management, and suggested amelioration measures
 - an assessment of how the flying-foxes reacted to the works, with particular detail on the most extreme response and average response, outlining any recommendations for what aspects of the works went well and what aspects did not work well
 - further management actions planned including a schedule of works
 - an assessment⁵ of how the community responded to the works, including details on the number and nature of complaints before and after the works
 - detail on any compensatory plantings undertaken or required
 - expenditure (financial and in-kind costs)
 - Plan evaluation and review (see Section 12).

⁵ A similar approach should be taken to pre-management engagement (see Section 3) to allow direct comparison, and responses should be assessed against success measures (Section 9) to evaluate success.

12. Evaluation and review

The Plan will have a scheduled review annually, which will include evaluation of management actions against measures shown in Section 8.

The following will trigger a reactive review of the Plan:

- completion of a management activity
- progression to a higher level of management
- changes to relevant policy/legislation
- new management techniques becoming available
- outcomes of research that may influence the Plan
- incidents associated with the camp.

Results of each review will be included in reports to OEH (as per reporting timing outlined in Section 10.4.1).

If the Plan is to remain current, a full review including stakeholder consultation and expert input will be undertaken in the final year of the Plan's life prior to being re-submitted to OEH.

13. Plan administration

13.1 Monitoring of the camp

Council staff currently monitor the camp on a quarterly basis to undertake a count of the numbers of flying foxes occurring within the camp throughout the year. All information is entered into the national flying fox monitoring program database.

This monitoring will be extended to include changes to the camp caused by the implementation of the buffer vegetation management plan (VMP) as identified in Section 8.2.1. Information recorded will include vegetation structure and composition in and around the camp, the extent and size of the camp area and surveying neighbours to record their responses to the delivery of the actions. Monitoring will occur before, during and after the VMP has been delivered.

13.2 Reporting

The Management Plan will have the following reporting framework:

- Reporting to the OEH on the status of the implementation of the Plan for Level 1 and Level 2 actions will occur in accordance with the process and timeframe specified in Section 11.
- Reporting as required by OEH and any licence agreements.

13.3 Management structure and responsibilities

Table 7 below provides details of the roles and responsibilities for Council Staff, specific contractors and experts planned to be involved in the implementation of the Plan.

A project health and safety plan that includes all relevant contact details will be developed prior to implementing the Plan.

Stonequarry Creek Flying-fox Camp Management Plan

Table 7: Roles and responsibilities

Role	Name	Required experience/approvals	Responsibilities/authority	Communication lines
Program Coordinator	Environmental Services Project Officer	Project management Human resource management Community engagement Reporting	Inform and consult with stakeholders and interested parties Community engagement Evaluate program Submit reports to OEH/DoE Ensure all landowners have provided consent prior to works	Reports to Manager Environmental Outcomes Direct reports: Project Manager
Project Manager	Environmental Outcomes Manager	Project management Team leadership and coordination Data management	Coordinate field teams and ensure all personnel are appropriately experienced and trained for their roles Induct all personnel to the program Collect and collate data Liaise with OEH and DoE Liaise with wildlife carers/veterinarians (for orphaned/injured wildlife only)	Reports to: Program Coordinator Direct reports: Supervisor, Contractor
Supervisor	TBC	Knowledgeable in flying-fox biology, behaviour and camp management (see Appendix 6 for detail) ABLV-vaccinated and trained in flying-fox rescue Team training, leadership and supervision	Pre- and post-management monitoring Surrounding camp monitoring Coordinate daily site briefings Coordinate daily activities Monitor flying-fox behaviour Rescue flying-foxes if required (and no carer/vet on site) Determine daily works end point Participate in management activities	Reports to: Project Manager Direct reports: Team members, Observers/support
Team member	TBC	Recommended ABLV-vaccinated (employer to assess risk) Ideally all team knowledgeable in flying-fox biology, behaviour and camp management however not required	Attend daily site briefings Participate in relevant management activities	Reports to: Supervisor Direct reports: Nil
Contractor [insert type e.g. arborist]	Bush Regenerator	Relevant licences and experience in field	Conduct specified activities (e.g. tree trimming) Adhere to all directions given by Supervisor	Reports to: Project Manager Direct reports: Nil
Observer/support	WIRES	Approval to access site	Provide care of injured/orphaned wildlife (under licence) if required	Reports to: Supervisor Direct reports: Nil
Flying-fox expert	TBC	See Appendix 6	On-site population assessment, monitor flying-fox behaviour and ensure compliance with the Plan.	Reports to: Supervisor Direct reports: Nil

13.4 Adaptive management

The Plan has an adaptive management approach to reflect changes in management approaches for Grey headed Flying Foxes and feedback received. This approach will be achieved through the following mechanisms:

- Review of advice received from OEH as part of its review of submitted reports.
- The review process of the document specified in Section 12 of this Plan.
- Review of feedback received from members of the community received through Council's consultation mechanisms.
- Any other advice received from experts in Grey Headed Flying Foxes

13.5 Funding commitment

The actions contained in Section 9 of this Plan are non-capital or require a low level expenditure apart from the Action regarding the preparation of the Habitat Plan. Funding for the implementation of this Plan will be identified following its completion.

14. References and additional resources

Aich, P, Potter, AA and Griebel, PJ 2009, 'Modern approaches to understanding stress and disease susceptibility: A review with special emphasis on respiratory disease', *International Journal of General Medicine*, vol. 2, pp. 19–32.

AIHW 2012, *Risk factors contributing to chronic disease*, Cat no. PHE 157, Australian Institute of Health and Welfare, viewed 12 January 2016, www.aihw.gov.au/WorkArea/DownloadAsset.aspx?id=10737421546.

Atlas of Living Australia 2015, viewed 12 January 2016, www.ala.org.au.

Australasian Bat Society 2013, viewed 12 January 2016, ausbats.org.au/.

Australian Museum 2010, *Little Red Flying-fox*, viewed 12 January 2016, australianmuseum.net.au/little-red-flying-fox.

AVA 2015, *Hendra virus*, Australian Veterinary Association, viewed 12 January 2016, www.ava.com.au/hendra-virus.

Birt, P 2000, 'Summary information on the status of the Grey-headed (*Pteropus poliocephalus*) and Black (*P. alecto*) Flying-Fox in New South Wales,' Proceedings of workshop to assess the status of the grey-headed flying-fox in New South Wales. University of Sydney, Sydney, New South Wales, Australia, pp. 78-86.

CDC 2014, *Hendra virus disease (HeV): Transmission*, Centers for Disease Control and Prevention, updated 17 March 2014, viewed 12 January 2016, www.cdc.gov/vhf/hendra/transmission/index.html.

Churchill, S 2008, *Australian Bats*, Allen & Unwin, Crows Nest, NSW.

DAF 2012, *Zoonoses are diseases that can spread from animals to people*, Queensland Department of Agriculture and Fisheries, updated 31 January 2012, viewed 12 January 2016, www.daf.qld.gov.au/animal-industries/animal-health-and-diseases/zoonoses.

DECC 2007, *Threatened species assessment guidelines: the assessment of significance*, Department of Environment and Climate Change NSW, Sydney, viewed 12 January 2016, www.environment.nsw.gov.au/resources/threatenedspecies/tsaguide07393.pdf.

DECC 2008, *Best practice guidelines for the grey-headed flying-fox*, Department of Environment and Climate Change NSW, Sydney, viewed 12 January 2016, www.environment.nsw.gov.au/resources/threatenedspecies/08540tsdsflyingfoxbpg.pdf.

DECCW 2009, *Draft National Recovery Plan for the Grey-headed Flying-fox Pteropus poliocephalus*, prepared by Dr Peggy Eby for Department of Environment, Climate Change and Water NSW, Sydney, viewed 12 January 2016, www.environment.nsw.gov.au/resources/threatenedspecies/08214dnrpflyingfox.pdf.

Den Exter, K, Roberts, B, Underwood, A and Martin, L 2011, *A discussion paper on flying foxes and the implications for bush regeneration at their camp sites*, Big Scrub Landcare, posted 28 March 2011, viewed 12 January 2016, bigscrubrainforest.org.au/?p=129.

DoE 2013, *Matters of National Environmental Significance: Significant Impact Guidelines 1.1*, Environment Protection and Biodiversity Conservation Act 1999, Australian Government Department of the Environment, www.environment.gov.au/system/files/resources/42f84df4-720b-4dcf-b262-48679a3aba58/files/nes-guidelines_1.pdf.

DoE 2014, *How can flying-foxes be managed in accordance with national environmental law?* Australian Government Department of the Environment, Canberra, viewed 12 January 2016, www.environment.gov.au/biodiversity/threatened/species/flying-fox-law.

Stonequarry Creek Flying-fox Camp Management Plan

- DoE 2015, *Referral guideline for management actions in grey-headed and spectacled flying-fox camps*, Australian Government Department of the Environment, Canberra, viewed 12 January 2016, www.environment.gov.au/system/files/resources/6d4f8ebc-f6a0-49e6-a6b6-82e9c8d55768/files/referral-guideline-flying-fox-camps.pdf.
- DoE 2016a, *Pteropus poliocephalus in Species Profile and Threats Database*, Australian Government Department of the Environment, Canberra, viewed 12 January 2016, www.environment.gov.au/cgi-bin/sprat/public/publicspecies.pl?taxon_id=186.
- DoE 2016b, *Monitoring Flying-fox Populations*, Australian Government Department of the Environment, Canberra, viewed 12 January, www.environment.gov.au/biodiversity/threatened/species/flying-fox-monitoring.
- DoEE 2008 Species profile and threats database, Department of the Environment and Energy, viewed 15 September 2017, available: http://www.environment.gov.au/cgi-bin/sprat/public/publicspecies.pl?taxon_id=12533
- DoEE 2017, EPBC Act Protected Matters Report, Australian Government
- DPI 2013, *Australian bat lyssavirus*, June 2013 Primefact 1291 2nd edition, Department of Primary Industries, NSW, viewed 12 January 2016, www.dpi.nsw.gov.au/_data/assets/pdf_file/0011/461873/Australian-Bat-lyssavirus.pdf.
- DPI 2014, *Hendra virus*, June 2014 Primefact 970 9th edition, Department of Primary Industries, NSW, viewed 12 January 2016, www.dpi.nsw.gov.au/_data/assets/pdf_file/0019/310492/hendra_virus_primefact_970.pdf.
- DPI 2015a, *Hendra virus*, Department of Primary Industries, NSW, viewed 12 January 2016, www.dpi.nsw.gov.au/agriculture/livestock/horses/health/general/hendra-virus.
- DPI 2015b, *Lyssavirus and other bat health risks*, Department of Primary Industries, Primary Industry Biosecurity, NSW, viewed 12 January 2016, www.dpi.nsw.gov.au/biosecurity/animal/humans/bat-health-risks.
- DSDIP 2014, *Queensland State Planning Policy July 2014*, Department of State Development, Infrastructure and Planning, Brisbane.
- Eby, P 1991, 'Seasonal movements of Grey-headed Flying-foxes, *Pteropus poliocephalus* (Chiroptera: Pteropodidae) from two maternity roosts in northern New South Wales', *Wildlife Research*, vol. 18, pp. 547–59.
- Eby, P 1995, *The biology and management of flying-foxes in NSW*, Species management report number 18, Llewellyn, L. (ed.), National Parks and Wildlife Service, Hurstville.
- Eby, P 2000, 'The results of four synchronous assessments of relative distribution and abundance of Grey-headed Flying-fox *Pteropus poliocephalus*', Proceedings from workshop to assess the status of the Grey-headed Flying-fox in New South Wales, pp. 66–77.
- Eby, P 2006, 'Site Management Plan for the Grey-headed Flying-fox camp at the Sydney Desalination Plant Site', report to Sydney Water Corporation, Sydney.
- Eby, P and Lunney, D 2002, *Managing the Grey-headed Flying-fox as a threatened species in NSW*, Royal Society of New South Wales, Darlington, NSW.
- Eby, P. 2016, 'Planting to conserve threatened nomadic pollinators in NSW', Office of Environment and Heritage, Sydney.
- Ecosure 2011, 'Hendra Virus Risk Assessment for the Gold Coast Equine Precinct: Residual Risk Report', unpublished report to City of Gold Coast.
- Ecosure 2014, *Cannes Reserve flying-fox management strategy*, Ecosure Pty Ltd, report to Pittwater Council, Sydney.

Stonequarry Creek Flying-fox Camp Management Plan

Ecosure 2014, 'Outcomes of a new flying-fox management framework: Review of management actions 2013–2014', unpublished data collected in collaboration with Griffith University (Industry Affiliates Program).

Edson, D, Field, H, McMichael, L, Jordan, D, Kung, N, Mayer, D and Smith, C 2015, 'Flying-fox Roost Disturbance and Hendra Virus Spillover Risk', *PLoS ONE*, vol. 10, no. 5, viewed 12 January 2016, www.ncbi.nlm.nih.gov/pmc/articles/PMC4446312/pdf/pone.0125881.pdf.

EHP 2012, *Living with Wildlife – Flying-foxes*, Department of Environment and Heritage Protection, Queensland, updated 14 May 2012, viewed 12 January 2016, www.ehp.qld.gov.au/wildlife/livingwith/flyingfoxes/importance.html.

EHP 2013a, *Code of Practice – Ecologically sustainable management of flying-fox roosts*, Department of Environment and Heritage Protection, Queensland, viewed 12 January 2016, www.ehp.qld.gov.au/wildlife/livingwith/flyingfoxes/roost-management.html.

EHP 2013b, *Code of Practice – Low impact activities affecting flying-fox roosts*, Department of Environment and Heritage Protection, Queensland, viewed 12 January 2016, www.ehp.qld.gov.au/wildlife/livingwith/flyingfoxes/roost-management.html.

EHP 2013c, *Flying-fox roost management guideline*, Department of Environment and Heritage Protection, Queensland, viewed 12 January 2016, www.ehp.qld.gov.au/wildlife/livingwith/flyingfoxes/roost-management.html.

ELW&P 2015, *Flying-foxes*, Department of Environment, Land, Water and Planning, State of Victoria.

EPA 2013, *Noise Guide for Local Government*, Environment Protection Authority, Sydney.

Fujita, MS 1991, 'Flying-fox (*Chiroptera: Pteropodidae*) pollination, seed dispersal, and economic importance: a tabular summary of current knowledge', *Resource Publication No. 2*, Bat Conservation International.

GeoLINK 2010, *Maclean Flying-fox Management Strategy*, report prepared for Clarence Valley Council on behalf of the Maclean Flying-Fox Working Group.

GeoLINK 2012, *Lorn Flying-fox management strategy*, report prepared for Maitland City Council.

Hall, L and Richards, G 2000, *Flying foxes: fruit and blossom bats of Australia*, UNSW Press, Sydney.

Henry, JP and Stephens-Larson, P 1985, 'Specific effects of stress on disease processes' in Moberg, GP (ed.), *Animal Stress*, American Physiological Society, pp.161–175.

IUCN 2015, *Little red flying-fox*, International Union for the Conservation of Nature, www.iucnredlist.org.

Ku-ring-gai Council 2013, *Ku-ring-gai Flying-fox Reserve Management Plan*, Ku-ring-gai Council, Gordon, NSW.

Lunney, D, Richards, G and Dickman, C 2008, *Pteropus poliocephalus*, The IUCN Red List of Threatened Species 2008: e.T18751A8554062, dx.doi.org/10.2305/IUCN.UK.2008.RLTS.T18751A8554062.en.

Lunney, D, Richards, G and Dickman, C 2008, *Pteropus poliocephalus*, in IUCN 2011, *IUCN Red List of Threatened Species*, Version 2011.2, viewed 12 January 2016, www.iucnredlist.org.

Markus, N 2002, 'Behaviour of the Black Flying-fox *Pteropus alecto*: 2. Territoriality and courtship', *Acta Chiropterologica*, vol. 4, no. 2, pp.153–166.

Markus, N and Blackshaw, JK 2002, 'Behaviour of the Black Flying-fox *Pteropus alecto*: 1. An ethogram of behaviour, and preliminary characterisation of mother-infant interactions', *Acta Chiropterologica*, vol. 4, no. 2, pp. 137–152.

Stonequarry Creek Flying-fox Camp Management Plan

Markus, N and Hall, L 2004, 'Foraging behaviour of the black flying-fox (*Pteropus alecto*) in the urban landscape of Brisbane, Queensland', *Wildlife Research*, vol. 31, no. 3, pp. 345-355.

McCall, BJ, Field, H, Smith, GA, Storie, GJ and Harrower, BJ 2005, 'Defining the risk of human exposure to Australian bat lyssavirus through potential non-bat animal infection', *CDI*, vol. 29, no. 2, pp. 200–203, [www.health.gov.au/internet/main/publishing.nsf/content/cda-cdi2902-pdf-cnt.htm/\\$FILE/cdi2902k.pdf](http://www.health.gov.au/internet/main/publishing.nsf/content/cda-cdi2902-pdf-cnt.htm/$FILE/cdi2902k.pdf).

McConkey, KR, Prasad, S, Corlett, RT, Campos-Arceiz, A, Brodie, JF, Rogers, H and Santamaria, L 2012, 'Seed dispersal in changing landscapes', *Biological Conservation*, vol. 146, pp. 1–13, doi:10.1016/j.biocon.2011.09.018.

McGuckin, MA and Blackshaw, AW 1991, 'Seasonal changes in testicular size, plasma testosterone concentration and body weight in captive flying-foxes (*Pteropus poliocephalus* and *P. scapulatus*)', *Journal of Reproduction and Fertility*, vol. 92, pp. 339–346.

McIlwee, AP and Martin, IL 2002, 'On the intrinsic capacity for increase of Australian flying-foxes', *Australian Zoologist*, vol. 32, no. 1.

Milne, DJ and Pavey, CR 2011, 'The status and conservation of bats in the Northern Territory', in Law, B, Eby, P, Lunney, D and Lumsden, L (eds), *The Biology and Conservation of Australasian Bats*, Royal Zoological Society of NSW, Mosman, NSW, pp. 208–225.

NSW Health 2012, *Flying foxes and health*, NSW Health, North Sydney, viewed 12 January 2016, www.health.nsw.gov.au/environment/factsheets/Pages/flying-foxes.aspx.

NSW Health 2013, *Rabies and Australian Bat Lyssavirus Infection*, NSW Health, North Sydney, viewed 12 January 2016, www.health.nsw.gov.au/Infectious/factsheets/Pages/Rabies-Australian-Bat-Lyssavirus-Infection.aspx.

OEH 2011a, *Grey-headed Flying-fox vulnerable species listing: NSW Scientific Committee final determination*, Office of Environment and Heritage, Sydney, viewed 12 January 2016, www.environment.nsw.gov.au/determinations/GreyheadedFlyingFoxVulSpListing.htm.

OEH 2011b, *NSW Code of Practice for Injured, Sick and Orphaned Protected Fauna*, Office of Environment and Heritage, Sydney, viewed 12 January 2016, www.environment.nsw.gov.au/resources/wildlifelicences/110004FaunaRehab.pdf.

OEH 2012, *NSW Code of Practice for Injured, Sick and Orphaned Flying-foxes*, Office of Environment and Heritage, Sydney, viewed 12 January 2016, www.environment.nsw.gov.au/resources/wildlifelicences/120026flyingfoxcode.pdf.

OEH 2012, *Threatened species*, Office of Environment and Heritage, viewed 15 September 2017, available: <http://www.environment.nsw.gov.au/topics/animals-and-plants/threatened-species>

OEH 2014, *BioBanking Assessment Methodology 2014*, Office of Environment and Heritage, Sydney, viewed 12 January 2016, www.environment.nsw.gov.au/resources/biobanking/140661BBAM.pdf.

OEH 2015a, *Flying-foxes* (including fact sheets), Office of Environment and Heritage, Sydney, viewed 12 January 2016, www.environment.nsw.gov.au/animals/flyingfoxes.htm.

OEH 2015b, *Flying-fox Camp Management Policy 2015*, Office of Environment and Heritage, Sydney, viewed 12 January 2016, www.environment.nsw.gov.au/resources/threatenedspecies/150070-flyingfoxcamp-policy.pdf.

OEH 2015c, *Flying-fox Camp Management Plan Template 2015*, Office of Environment & Heritage, Sydney, viewed 12 January 2016, www.environment.nsw.gov.au/resources/threatenedspecies/150102-flyingfoxcamp-template.pdf.

OEH 2015d, *GHFF threatened species profile*, Office of Environment and Heritage, Sydney, viewed 12 January 2016, www.environment.nsw.gov.au/threatenedSpeciesApp/profile.aspx?id=10697

Stonequarry Creek Flying-fox Camp Management Plan

OEH 2015e, *Policy and procedural guidelines for the mitigation of commercial crop damage by flying-foxes*, Office of Environment and Heritage, Sydney, viewed 12 January 2016, www.environment.nsw.gov.au/resources/wildlifelicences/140480FlyfoxPol.pdf

OEH 2017, *NSW Bionet: the website for the Atlas of NSW Wildlife*, Office of Environment and Heritage, viewed 15 September 2017, available: <http://www.bionet.nsw.gov.au/>

OEH 2017a, *Threatened species*, Office of Environment and Heritage, viewed 15 September 2017, available: <http://www.environment.nsw.gov.au/topics/animals-and-plants/threatened-species>

Parry-Jones, KA and Augee, ML 1992, 'Movements of the Grey-headed Flying Foxes (*Pteropus poliocephalus*) to and from a colony site on the central coast of New South Wales', *Wildlife Research*, vol. 19, pp. 331–40.

Parry-Jones, K and Augee, M 2001 'Factors affecting the occupation of a colony site in Sydney, New South Wales by the Grey-headed Flying-fox *Pteropus poliocephalus* (Pteropodidae)', *Austral Ecology*, vol. 26, pp. 47–55.

Pierson, ED and Rainey, WE 1992, 'The biology of flying foxes of the genus *Pteropus*: A Review', in: Wilson, DE and GL Graham (eds), *Pacific Island Flying Foxes: Proceedings of an International Conservation Conference*, US Department of the Interior – Biological Report no. 90, pp. 1–17.

Qld Health 2016, *Bats and Human Health*, Queensland Health, viewed 12 January 2016, www.health.qld.gov.au/communicablediseases/hendra.asp

Ratcliffe, F 1932, 'Notes on the Fruit Bats (*Pteropus* spp.) of Australia', *Journal of Animal Ecology*, vol. 1, no. 1, pp. 32–57.

Roberts, B 2005, 'Habitat characteristics of flying-fox camps in south-east Queensland', BSc. Honours Thesis, Griffith University, Brisbane.

Roberts, BJ 2006, *Management of Urban Flying-fox Roosts: Issues of Relevance to Roosts in the Lower Clarence, NSW*, Valley Watch Inc, Maclean.

Roberts, B and Eby, P 2013, Review of past flying-fox dispersal actions between 1990–2013, publisher unknown, viewed 12 January 2016, www.environment.nsw.gov.au/resources/animals/flying-fox-2014-sub/subs/flyingfoxsub-jenny-beatson-part2.pdf.

Roberts, BJ, Catterall, CP, Eby, P and Kanowski, J 2012, 'Long-Distance and Frequent Movements of the Flying-Fox *Pteropus poliocephalus*: Implications for Management', *PLoS ONE*, vol. 7, no. 8, e42532.

Roberts, BJ, Eby, P, Catterall, CP, Kanowski, J and Bennett, G 2011, 'The outcomes and costs of relocating flying-fox camps: insights from the case of Maclean, Australia', in Law, B, Eby, P, Lunney, D and Lumsden, L (eds), *The Biology and Conservation of Australasian Bats*, Royal Zoological Society of NSW, Mosman, NSW, viewed 12 January 2016, www.griffith.edu.au/data/assets/pdf_file/0006/358440/Roberts-et-al.pdf.

Roberts, B, Kanowski, J and Catterall, C 2006, *Ecology and Management of Flying-fox Camps in an Urbanising Region*, Rainforest CRC Tropical Forest Landscapes, Issue 5, viewed 12 January 2016, www.rainforest-crc.jcu.edu.au/issues/ITFL_flyingfox.pdf.

Robinson, L 2003, *Field Guide to the native plants of Sydney*. Third Edition. Kangaroo Press, Sydney.

SEQ Catchments 2012, *Management and Restoration of flying-fox Roosts: Guidelines and Recommendations*, SEQ Catchments Ltd funded by the Australian Government's Caring for Our Country, viewed 12 January 2016, www.environment.nsw.gov.au/resources/animals/flying-fox-2014-sub/subs/flyingfoxsub-jenny-beatson-part3.pdf.

Shinwari, MW, Annand, EJ, Driver, L, Warrilow, D, Harrower, B, Allcock, RJN, Pukallus, D, Harper J, Bingham, J, Kung, N and Diallo, IS 2014, 'Australian bat lyssavirus infection in two horses', *Veterinary Microbiology*, vol. 173, pp. 224–231.

Stonequarry Creek Flying-fox Camp Management Plan

Southerton, SG, Birt, P, Porter, J and Ford, HA 2004, 'Review of gene movement by bats and birds and its potential significance for eucalypt plantation forestry', *Australian Forestry*, vol. 67, no. 1, pp. 45–54.

Stanvic, S, McDonald, V and Collins, L 2013, *Managing heat stress in flying-foxes colonies*, viewed 12 January 2016, www.fourthcrossingwildlife.com/HeatStress-StanvicMcDonaldCollins.pdf.

Tait, J, Perotto-Baldivieso, HL, McKeown, A and Westcott, DA 2014, 'Are Flying-Foxes Coming to Town? Urbanisation of the Spectacled Flying-Fox (*Pteropus conspicillatus*) in Australia', *PLoS ONE*, vol. 9, no. 10, e109810, doi:10.1371/journal.pone.0109810.

Tidemann, C, Eby, P, Parry-Jones, K and Vardon, M 1999, *The Action Plan for Australian Bats: Grey-headed Flying-fox*, Environment Australia, www.environment.gov.au/node/14622.

Tolga Bat Hospital, *Wildlife Friendly Fencing Project*, Tolga Bat Hospital partly funded by grants from WWF and Australian Government Caring for Our Country, viewed 12 January, 2016, www.wildlifefriendlyfencing.com/WFF/Home.html.

Vardon, MJ and Tidemann, CR 1999, 'Flying-foxes (*Pteropus alecto* and *P. scapulatus*) in the Darwin region, north Australia: patterns in camp size and structure', *Australian Journal of Zoology*, vol. 47, pp. 411–423.

Vardon, MJ, Brocklehurst, PS, Woinarski, JCZ, Cunningham, RB, Donnelly, CF and Tidemann, CR 2001, 'Seasonal habitat use by flying-foxes, *Pteropus alecto* and *P. Scapulatus* (Megachiroptera), in monsoonal Australia', *Journal of Zoology* London, vol. 253, pp. 523–535.

Webb, N and Tidemann, C 1995, 'Hybridisation between black (*Pteropus alecto*) and grey-headed (*P. poliocephalus*) flying-foxes (Megachiroptera: Pteropodidae)', *Australian Mammalogy*, vol. 18, pp. 19–26.

Webb, NJ and Tidemann, CR 1996, 'Mobility of Australian flying-foxes, *Pteropus* spp. (Megachiroptera): evidence from genetic variation', *Proceedings of the Royal Society London Series B*, vol. 263, pp. 497–502.

Welbergen, JA 2014, 'Canaries in the coalmine: flying-foxes and extreme heat events in a warming climate', presentation at the Griffith Climate Change Seminar, July 2014, www.griffith.edu.au/research/research-excellence/griffith-climate-change-response-program/program/?a=628188.

Welbergen, JA, Klose, SM, Markus, N and Eby, P 2008, 'Climate change and the effects of temperature extremes on Australian flying-foxes', *Proceedings of the Royal Society of London B: Biological Sciences*, vol. 275, no. 1633, pp.419–425, viewed 12 January 2016, rspb.royalsocietypublishing.org/content/275/1633/419.short.

Westcott, DA, Dennis, AJ, Bradford, MG, McKeown, A and Harrington, GN 2008, 'Seed dispersal processes in Australia's Wet Tropics rainforests', in Stork, N and Turton, S, *Living in a dynamic tropical forest landscape*, Blackwells Publishing, Malden, pp. 210–223.

Westcott, DA, McKeown, A, Murphy, HT and Fletcher, CS 2011, *A monitoring method for the Grey-headed Flying-fox, Pteropus poliocephalus*, CSIRO, Queensland, viewed 12 January 2016, www.environment.gov.au/biodiversity/threatened/species/pubs/310112-monitoring-methodology.pdf.

Zurbuchen, A, Landert, L, Klaiber, J, Muller, A, Hein, S and Dorn, S 2010, 'Maximum foraging ranges in solitary bees: only few individuals have the capability to cover long-foraging distances', *Biological Conservation*, vol. 142, no. 3, pp. 669–676.

Appendix 1: Living with Flying-foxes flyer

Living near Flying Foxes!

Flying fox camps are increasingly setting up near towns and people because of the loss of their natural habitat and in response to local food availability. These camps can be challenging for the people that live near them.

Why have the flying foxes come to camp at Stonequarry Creek?

Flying fox camps are usually found in cool areas where there is a closed canopy of at least 5 metres tall with understorey and mid storey layers, near water and of a size of at least 1 Ha. One of the key features of this part of Stonequarry Creek is the steep sloping narrow sides of the creek bank and dense vegetation cover.

Can Council move them on?

Flying foxes are an important part of our ecosystem and are a protected species across Australia.

Approval is required from the State Government before anyone can disturb or relocate their camps or modify their habitat. In some cases, further approval may be required from the Federal Government.

Moving on Flying fox camps is usually unsuccessful. Where dispersal activities have occurred in other parts of the state, the flying foxes have often returned the following season.

Disease Risks for People and Animals

The risk of flying foxes transmitting disease to humans is extremely low as infection can only occur if you are bitten or scratched, so it is very important that you never handle them. Disease is not spread

through droppings or urine, so there is no risk if a flying fox flies overhead, feeds or roosts in your garden, or if you live near a camp or visit one.

Lyssavirus and Hendra virus are two diseases potentially associated with flying foxes. You can find out more information about these viruses from NSW Health's website:

- Hendra Virus - www.health.nsw.gov.au/Infectious/factsheets/Pages/Hendra_virus.aspx
- Lyssavirus - www.health.nsw.gov.au/Infectious/factsheets/Pages/Rabies-Australian-Bat-Lyssavirus-Infection.aspx

Bites or scratches from flying foxes: If you are bitten or scratched by a flying fox, gently but thoroughly wash the wound immediately with soap and water for at least five minutes. Apply an antiseptic such as Povidone-iodine and consult a doctor as soon as possible.

Pets

According to the Australian Animal Health Laboratory there have been no reports of illness in pets caused by eating deceased flying foxes. However, pets should be kept away from flying foxes if possible to reduce likelihood of scratches or bites. If a pet becomes sick after contact with a flying fox, seek advice from a veterinarian. There is no evidence of dog to human transmission of Hendra virus.

Water Safety

There is no evidence that a flying fox camp has any impact on publicly available drinking water provided by local authorities. The water continues to be treated and this eliminates any contamination from additional flying fox faeces in the catchment.

If you live under the flying fox flight path it is likely that faeces will be washed into your rainwater tanks when it rains. NSW Health recommends against drinking water from rainwater tanks where there is public drinking water available. Advice on safely managing rainwater for drinking purposes where there is no alternative supply is available on the NSW Health website -

www.health.nsw.gov.au/environment/water/Pages/rainwater.aspx

For more information contact Councils Environment Section 4677 1100

Noise and smell

Flying foxes are noisy animals, but this noise is an important part of their society. When flying foxes are present in large numbers, this noise can understandably be a nuisance for residents.

They can also be smelly, particularly when many are present. Although this smell may be unpleasant to us, it is an important way that flying foxes communicate with each other, including between mother and baby.

Stonequarry Creek Flying-fox Camp Management Plan

Faeces

Flying foxes excrete either during flight or while holding onto a branch by their wing claws. The flying fox digestive system is much faster than a human system and their waste is primarily liquid.

Tips and Hints

- Don't disturb the flying foxes. When flying foxes get stressed, they tend to squabble and make even more noise. They are quietest when left alone.

Drying your clothes outdoors:

- Avoid hanging out your washing when flying foxes are leaving and returning to their camp. This is usually around sunrise and sunset however it may be useful to note the approximate times the flying foxes are leaving and returning. This will give you some level of control knowing when you will need to ensure your washing is brought in off the line.
- Some residents have chosen to cover their washing with a tarpaulin to protect it.
- To remove flying fox faeces from your washing, treat them like fruit stains. Soak the item as soon as possible (preferably while the stain is still wet) in a good stain remover. Unfortunately some fruits with strong coloured flesh (e.g. mulberries) may leave a permanent stain.

Cars and other painted or outdoor surfaces:

- To avoid the potential for damage to painted surfaces around your home such as cars and garden furniture it is recommended to remove the faeces regularly with soapy water before it dries.

Vegetation in your garden:

- Flying foxes prefer tall vegetation, so they may be deterred by trimming vegetation and removing branches from around houses or public buildings. If flying foxes have already set up camp in trees, contact the Office of Environment and Heritage (OEH) on 131 555 before trimming any of these trees.
- Planting a buffer of low vegetation, such as shrubs on your property can provide a screen between your house and flying foxes.
- Plant food trees preferred by flying foxes away from houses and orchards.

Useful Links:

Office of Environment and Heritage - www.environment.nsw.gov.au/topics/animals-and-plants/native-animals/native-animal-facts/flying-foxes

NSW Health - www.health.nsw.gov.au/environment/factsheets/Pages/flying-foxes.aspx

Department of Primary Industries - www.dpi.nsw.gov.au/animals-and-livestock/horses/health-and-disease/hendra-virus

Appendix 2: Summary of other key legislation likely to apply at some camps

Local government legislation

Local government is required to prepare planning schemes (including Environmental Planning Instruments and Development Control Plans) consistent with provisions under the *Environmental Planning and Assessment Act 1979* (EP&A Act; see Section 4.1.5 of the template).

Local Environment Plans are environmental planning instruments that are legal documents and that relate to a local government area. Other environmental planning instruments, such as State Environmental Planning Policies (SEPPs), may relate to the whole or part of the state. A development control plan provides detailed planning and design guidelines to support the planning controls in a Local Environment Plan, but they are not legal documents.

Planning schemes enable a local government authority to manage growth and change in their local government area (LGA) through land use and administrative definitions, zones, overlays, infrastructure planning provisions, assessment codes and other administrative provisions. A planning scheme identifies the kind of development requiring approval, as well as zoning all areas within the LGA based on the environmental values and development requirements of that land. Planning schemes could potentially include a flying-fox habitat overlay, and may designate some habitat as flying-fox conservation areas.

State legislation

Rural Fires Act 1997

The objects of this Act are to prevent, mitigate and suppress bushfires and coordinate bush firefighting, while protecting persons from injury or death, and reduce property damage from fire. A permit is generally required from the Rural Fire Service for any fires in the open that are lit during the local Bush Fire Danger Period as determined each year. This may be relevant for fires used to disperse flying-foxes, or for any burning associated with vegetation management.

Protection of the Environment Operations Act 1997

The main object of the *Protection of the Environment Operations Act 1997* (POEO Act) is to set out explicit protection of the environment polices (PEPs) and adopt more innovative approaches to reducing pollution.

The use of smoke as a dispersal mechanism may constitute 'chemical production' under Schedule 1, clause 8 of the POEO Act, so this type of dispersal activity may require a licence under Chapter 3 of the Act.

The POEO Act also regulates noise including 'offensive noise'. The Protection of the Environment Operations (Noise Control) Regulation 2008 (Part 4, Division 2) provides information on the types of noise that can be 'offensive' and for which the Environment Protection Authority (EPA) can issue fines. This may include noise generated as a part of dispersal activities. It is best to discuss the types of noise makers and the sound levels and times these will be generated, along with identified noise receptors, with Council prior to any dispersal. Detailed advice and guidance on noise regulation can be found in the EPA's *Noise guide for local government* (EPA 2013).

Crown Lands Act 1989

The principles of Crown land management include the observance of environmental protection principles and the conservation of its natural resources, including water, soil, flora, fauna and scenic quality. Any works on land that is held or reserved under the Crown Lands Act 1989

(including vegetation management and dispersal activities) are an offence under the Act without prior authorisation obtained through the Department of Primary Industries (Lands).

Local Government Act 1993

The primary purpose of this Act is to provide the legal framework for an effective, efficient and environmentally responsible, open system of local government. Most relevant to flying-fox management is that it also provides encouragement for the effective participation of local communities in the affairs of local government and sets out guidance on the use and management of community land which may be applicable to land which requires management of flying-foxes.

State Environmental Planning Policies

SEPPs are environmental planning instruments which address specific planning issues within NSW. These SEPPs often remove power from local councils in order to control specific types of development or development in specific areas. SEPPs often transfer decision-making from Council to the Planning Minister. While there may be others, some of the SEPPs likely to apply at some flying-fox camps are outlined below.

SEPP 14 – Coastal Wetlands

This policy provides additional protection for coastal wetlands by requiring development consent to be obtained before any clearing, draining, filling or construction of levees can occur on a mapped wetland. Camps are unlikely to fall within the bounds of a SEPP 14 wetland, but additional restrictions for vegetation management in these areas may be required if they do.

SEPP 26 – Littoral Rainforests

SEPP 26 aims to protect coastal rainforests (littoral rainforests) by requiring development consent for activities within or adjacent to mapped coastal rainforest. It is unlikely that clearing for flying-fox management would be considered significant enough to trigger this SEPP but this should be confirmed if the site is within a mapped SEPP 26 area.

SEPP 19 – Bushland in Urban Areas

The aim of this policy is to protect and preserve bushland within urban areas which are defined in Schedule 1 of the SEPP. Broadly, this covers most LGAs within the Greater Sydney Region. It does not cover:

- land reserved or dedicated under the *National Parks and Wildlife Act 1974*
- state forests, flora reserves or timber reserves under the *Forestry Act 1916*
- land to which SEPP (Western Sydney Parklands) 2009 applies.

Bushland within the designated LGAs may not be disturbed without the consent of the council unless the disturbance is for: bushfire hazard reduction, facilitating recreational use of the bushland in accordance with a plan of management referred to in clause 8 of the policy and essential infrastructure such as electricity, sewerage, gas or main roads. If the land owned by the proponent is zoned as SEPP 19 bushland, council approval would be required under this SEPP. Council should be contacted to discuss any potential disturbance associated with camp management.

Appendix 3: Flora and fauna records (NSW Bionet)

Family	Scientific name	Common name	NSW Status	Comm Status	Habitat description	Likelihood of occurrence
Fauna						
Meliphagidae	<i>Anthochaera phrygia</i>	Regent Honeyeater	E4	CE	Box-Ironbark eucalypt woodland and dry sclerophyll forest associations in areas of low to moderate relief	Unlikely Site habitat quality too poor to support this species although this bird could be an itinerant vagrant taking advantage of the seasonal availability of nectar.
Ardeidae	<i>Ardea ibis</i>	Cattle Egret	P	C,J	The cattle egret occurs in tropical and temperate grasslands, wooded lands and terrestrial wetlands. It is commonly associated with the habitats of farm animals, particularly cattle, but also pigs, sheep, horses and deer. The cattle egret is known to follow earth-moving machinery and has been located at rubbish tips. It uses predominately shallow, open and fresh wetlands including meadows and swamps with low emergent vegetation and abundant aquatic flora. They have sometimes been observed in swamps with tall emergent vegetation	Unlikely The site does not support suitable habitat for this species as it prefers wide open spaces, woodlands and terrestrial wetlands.
Apodidae	<i>Hirundapus caudacutus</i>	White-throated Needletail	P	C,J,K	Although they occur over most types of habitat, they are probably recorded most often above wooded areas, including open forest and rainforest, and may also fly between trees or in clearings, below the canopy, but they are less commonly recorded flying above woodland.	Possible Likely to be observed overhead of the site and may rarely forage amongst the canopy.
Meropidae	<i>Merops ornatus</i>	Rainbow Bee-eater	P	J	Occurs mainly in open forest, woodlands and shrublands and partially cleared habitats.	Unlikely This migratory species prefers more open flatter environments than what is available at Stonequarry Creek.
Accipitridae	<i>Hieraaetus morphnoides</i>	Little Eagle	V	Not listed	Occupies open eucalypt forest, woodland or open woodland. Sheoak, Acacia woodlands and riparian woodlands of interior NSW are	Unlikely Site habitat is too degraded and within a semi-urban environment to support this

Stonequarry Creek Flying-fox Camp Management Plan

Family	Scientific name	Common name	NSW Status	Comm Status	Habitat description	Likelihood of occurrence
					also used.	raptor.
Climacteridae	<i>Climacteris picumnus victoriae</i>	Brown Treecreeper (eastern subspecies)	V	Not listed	Found in eucalypt woodlands (including Box-Gum Woodland) and dry open forest of the inland slopes and plains inland of the Great Dividing Range; mainly inhabits woodlands dominated by stringybarks or other rough-barked eucalypts, usually with an open grassy understorey, sometimes with one or more shrub species; also found in mallee and River Red Gum (<i>Eucalyptus camaldulensis</i>) Forest bordering wetlands with an open understorey of acacias, saltbush, lignum, cumbungi and grasses; usually not found in woodlands with a dense shrub layer; fallen timber is an important habitat component for foraging; also recorded, though less commonly, in similar woodland habitats on the coastal ranges and plains.	Possible Limited habitat available but there is a chance that this bird could forage in the better quality habitat particularly on some of the rough barked eucalypts such as <i>Angophora floribunda</i> .
Neosittidae	<i>Daphoenositta chrysoptera</i>	Varied Sittella	V	Not listed	Eucalypt forest and dry, open forest.	Possible Limited suitable habitat available on the banks and slopes of the creek.
Artamidae	<i>Artamus cyanopterus cyanopterus</i>	Dusky Woodswallow	V	Not listed	Primarily inhabit dry, open eucalypt forests and woodlands, including mallee associations, with an open or sparse understorey of eucalypt saplings, acacias and other shrubs, and ground-cover of grasses or sedges and fallen woody debris. It has also been recorded in shrublands, heathlands and very occasionally in moist forest or rainforest. Also found in farmland, usually at the edges of forest or woodland.	Possible May be an itinerant visitor to the site as it prefers a wide range of habitats.
Petroicidae	<i>Melanodryas cucullata cucullata</i>	Hooded Robin (south-eastern form)	V	Not listed	Usually occurs in open eucalypt woodland, acacia shrub and mallee, in or near clearings.	Possible Some limited habitat available for this species particularly along the mid to upper slopes where better quality habitat is available.

Stonequarry Creek Flying-fox Camp Management Plan

Family	Scientific name	Common name	NSW Status	Comm Status	Habitat description	Likelihood of occurrence
	<i>Petroica boodang</i>	Scarlet Robin	V	Not listed	Dry eucalypt forest and woodland. Prefers understorey with few scattered shrubs and grassland.	Possible Some limited habitat available for this species particularly along the mid to upper slopes where better quality habitat is available.
Estrildidae	<i>Stagonopleura guttata</i>	Diamond Firetail	V	Not listed	Open eucalypt, forest woodlands, river redgums, mallee, buloke, cypress pine, acacia scrubs, citrus orchards.	Possible Some limited habitat available for this species particularly along the mid to upper slopes where better quality habitat is available.
Cacatuidae	<i>Calyptorhynchus lathami</i>	Glossy Black-Cockatoo	V	Not listed	Highly dependent on Allocasuarina species, Open forest and woodlands with stands of sheoak (especially <i>Allocasuarina littoralis</i> and <i>Allocasuarina torulosa</i>). They mostly roost in the canopy of live, leafy trees such as eucalypts but breed in a hollow stump or limb of living or dead trees as well as holes in trunks of tall trees	Possible <i>Allocasuarina littoralis</i> is present and so this species may forage on the site.
Accipitridae	<i>Lophoictinia isura</i>	Square-tailed Kite	V	Not listed	Inhabits a range of diverse habitats including woodland dominated by eucalypts, pandanus, gallery forest, heath.	Possible May utilise the site for foraging and can often be seen in urban and semi-urban environments.
Cacatuidae	<i>Callocephalon fimbriatum</i>	Gang-gang Cockatoo	V	Not listed	Tall mountain forests in spring and summer, heavily timbered and mature wet sclerophyll.	Unlikely Suitable habitat not available, the vegetation is too disturbed and dry to be considered suitable habitat for the gang-gang cockatoo.
Strigidae	<i>Ninox strenua</i>	Powerful Owl	V	Not listed	Open forests and woodlands, particularly in wet forests with dense understoreys and along watercourses	Possible Given the large home range of the Powerful owl it is likely that the site could be used for foraging .
Camaenidae	<i>Meridolum corneovirens</i>	Cumberland Plain Land Snail	E1	Not listed	Primarily inhabits Cumberland Plain Woodland which is a grassy open woodland with some dense shrubs.	Unlikely Site is too disturbed and modified to provide suitable habitat for the land snail.

Stonequarry Creek Flying-fox Camp Management Plan

Family	Scientific name	Common name	NSW Status	Comm Status	Habitat description	Likelihood of occurrence
Pseudocheiridae	<i>Petauroides volans</i>	Greater Glider		V	Nest in hollows of tall trees, emerging at night to feed on eucalypt leaves and flower buds.	Unlikely Suitable hollows are not available to support a population of greater gliders and is not well connected to surrounding habitat.
Petauridae	<i>Petaurus australis</i>	Yellow-bellied Glider	V	Not listed	Occurs in tall, damp Eucalypt forest and mixed coastal forests.	Unlikely This small patch of forest in an urban environment is very unlikely to support the yellow-bellied glider. Poor connectivity, poor habitat quality in an urban environment provides minimal resources for this glider.
	<i>Petaurus norfolcensis</i>	Squirrel Glider	V	Not listed	Inhabits mature or old growth Box, Box-Ironbark woodlands and River Red Gum forest west of the Great Dividing Range and Blackbutt-Bloodwood forest with heath understorey in coastal areas.	Unlikely Highly disturbed young eucalypt forest provides limited denning and foraging opportunities for the squirrel glider.
Molossidae	<i>Mormopterus norfolkensis</i>	Eastern Freetail-bat	V	Not listed	This species inhabits dry sclerophyll forest, woodland, riparian vegetation, rainforest, wet sclerophyll forest, swamp forests and mangrove forests east of the Great Dividing Range. It is known to roost in tree hollows but will also roost under bark or in man-made structures. Occurs in moist eucalypt forest, rainforest, vine thicket, wet and dry sclerophyll forest, melaleuca swamps, dense coastal forests and banksia scrub.	Possible This bat could use the site for foraging along the creek and banks although it prefers wetter vegetation types. Possible roost sites under bark but there are no tree hollows available.
Vespertilionidae	<i>Miniopterus australis</i>	Little Bentwing-bat	V	Not listed	Diverse, including Moist Eucalypt forest, rainforest, coastal forest, Melaleuca swamp and wet and dry sclerophyll forest.	Possible This bat could use the site for foraging along the creek and banks although it prefers wetter vegetation types.
	<i>Miniopterus schreibersii oceanensis</i>	Eastern Bentwing-bat	V,P	Not listed	This species occurs in woodlands and forests where it hunts above the canopy. It roosts mostly in caves but will also use derelict mines, storm water tunnels, buildings and man-made structures. Maternity caves are	Possible This bat could use the site for foraging along the creek and banks although it prefers wetter vegetation types. There are very limited opportunities for roosting

Stonequarry Creek Flying-fox Camp Management Plan

Family	Scientific name	Common name	NSW Status	Comm Status	Habitat description	Likelihood of occurrence
					restricted to caves with specific temperature and humidity ranges. This species often roosts in colonies with up to 150,000 individuals.	with no obvious caves or shelters available.
	<i>Myotis macropus</i>	Southern Myotis	V,P	Not listed	Roosts close to water in caves, mine shafts, tree hollows, storm water channels, under bridges and in dense foliage.	Possible Although this species roosts close to water, there are no suitable structures available at the site. Some limited foraging habitat may be available.
	<i>Chalinolobus dwyeri</i>	Large-eared Pied Bat	V,P	V	Dry forests and woodlands, moist eucalypt forests, caves and mines	Unlikely This bat could use the site for foraging along the creek and banks. Suitable roosting sites are not present.
Phascolarctidae	<i>Phascolarctos cinereus</i>	Koala	V,P	V	The koala occurs in a range of temperate, sub-tropical and tropical forest, woodland and semi-arid communities dominated by eucalyptus trees. Koalas feed almost exclusively on a few preferred primary and secondary food tree species that may vary widely on a regional, local and possibly seasonal basis.	Possible There are scattered records in the vicinity of Picton so it is not unreasonable to assume that the species would use the site infrequently. There are enough scattered eucalypts to provide suitable food resources.
Flora						
Apocynaceae	<i>Cynanchum elegans</i>	White-flowered Wax Plant	E1	E	Occurs on a variety of soil types on steep slopes with a range of soil fertility (DoEE 2008)	Possible Suitable habitat is available for this climber amongst the rocky scree slopes.
Elaeocarpaceae	<i>Tetraloche glandulosa</i>		V	Not listed	Associated with shale-sandstone transition habitat, occupies ridgetops and upper slopes in generally shallow soils.	Possible This short spreading shrub grows in sandy or rocky heath, limited habitat available as a result of significant disturbance
Ericaceae	<i>Epacris purpurascens</i> var. <i>purpurascens</i>		V	Not listed	Found in a range of habitats mainly with strong shale soil influence.	Unlikely This plant is found a wide range of habitats with a strong shale influence, conditions not found at the subject site

Stonequarry Creek Flying-fox Camp Management Plan

Family	Scientific name	Common name	NSW Status	Comm Status	Habitat description	Likelihood of occurrence
	<i>Leucopogon exolasius</i>	Woronora Beard-heath	V	V	Inhabits woodland on sandstone and prefers rocky hillsides along creek banks.	Unlikely Grows in woodland on sandstone conditions not found at the subject site
Myrtaceae	<i>Darwinia peduncularis</i>		V	Not listed	Found on or near rocky outcrops on sandy, well drained ow nutrient soil over sandstone.	Possible This plant prefers dry sclerophyll forest on sandstone hillsides. Some habitat potentially available on the upper slopes.
	<i>Darwinia biflora</i>		V	V	Occurs on edges of weathered shale-capped ridges, integrated with Hawkesbury Sandstone.	Unlikely This erect shrub occurs on the edges of weathered shale-capped ridges, a habitat type not available at the subject site.
	<i>Eucalyptus camfieldii</i>	Camfield's Stringybark	V	V	This species occurs in poor coastal country in shallow sandy and poorly drained soils overlying Hawkesbury sandstone, associated with coastal heath mostly on exposed sandy ridges. It is found mostly in small scattered stands near the boundary of tall coastal heaths and low open woodland of the slightly more fertile inland areas (Robinson 2003).	Unlikely A mallee tree with restricted distribution on shallow sandy soils. Conditions not suitable at subject site.
	<i>Melaleuca deanei</i>	Deane's Paperbark	V	V	The species is endemic to the coastal areas of Greater Sydney and grows ridgetop woodland with a minor number occurring in heath on sandstone.	Unlikely This shrub occurs in ridgetop woodland with only 5% of sites in heath on sandstone. Suitable habitat not available.
	<i>Eucalyptus macarthurii</i>	Paddys River Box, Camden Woollybutt	E1	E	Occurs on grassy woodland on relatively fertile soils on broad cold flats.	Unlikely Suitable habitat not available, occurs on grassy woodland on relatively fertile soils
	<i>Syzygium paniculatum</i>	Magenta Lilly Pilly	E1	V	Only occurs in NSW: south coast – on grey soils over sandstone in mainly littoral rainforest, central coast – gravels, sands, silts and clays I n littoral and gallery rainforests.	Possible Some of the cooler areas would have once supported patches of rainforest potentially providing suitable habitat for this species
Polygonaceae	<i>Persicaria elatior</i>	Tall Knotweed	V	V	Found along streams and lakes and occasionally in swamp forest.	Possible This erect herb occurs in damp places, usually on the margin of standing water.

Stonequarry Creek Flying-fox Camp Management Plan

Family	Scientific name	Common name	NSW Status	Comm Status	Habitat description	Likelihood of occurrence
						Stonequarry creek may provide some suitable habitat
Proteaceae	<i>Grevillea parviflora</i> subsp. <i>parviflora</i>	Small-flower Grevillea	V	V	Sandy or light clay soils over thin shales. In the Sydney region, usually on tertiary sands and alluvium.	Possible A low spreading erect shrub which grows in sandy or light clay soils usually over this shales. Small areas of suitable habitat available
	<i>Persoonia bargoensis</i>	Bargo Geebung	E1	V	Woodland or dry sclerophyll forest on sandstone and heavier well drained loamy soils.	Possible Some suitable habitat available
	<i>Persoonia hirsuta</i>	Hairy Geebung	E1	E	The hairy geebung is restricted to the Greater Sydney district and can be found on ridge tops in sandy soils in dry sclerophyll open forest, woodland and heath on sandstone. It is usually present as isolated individuals or very small populations in disturbed areas such as track edges.	Possible Suitable habitat available along the top of the ridges although highly modified habitat would limit occurrence
Thymelaeaceae	<i>Pimelea curviflora</i> var. <i>curviflora</i>		V	V	The species occurs on shaley/lateritic soils over sandstone and shale/sandstone transition soils on ridgetops and upper slopes amongst woodlands. It often grows amongst dense grasses and sedges and responds to disturbance such as fire or grazing. It has also been observed in heath and woodland on sandstone (Robinson 2003).	Possible This shrub grows in a range of habitats potentially available at the subject site. Significant modification of habitat would limit its chances of being detected.

Appendix 4: EPBC Act Protected Matters Search report



Australian Government
Department of the Environment and Energy

EPBC Act Protected Matters Report

This report provides general guidance on matters of national environmental significance and other matters protected by the EPBC Act in the area you have selected.

Information on the coverage of this report and qualifications on data supporting this report are contained in the caveat at the end of the report.

Information is available about [Environment Assessments](#) and the EPBC Act including significance guidelines, forms and application process details.

Report created: 15/09/17 15:42:32

[Summary](#)

[Details](#)

[Matters of NES](#)

[Other Matters Protected by the EPBC Act](#)

[Extra Information](#)

[Caveat](#)

[Acknowledgements](#)



This map may contain data which are
©Commonwealth of Australia
(Geoscience Australia), ©PSMA 2010

[Coordinates](#)

Buffer: 10.0Km



Summary

Matters of National Environmental Significance

This part of the report summarises the matters of national environmental significance that may occur in, or may relate to, the area you nominated. Further information is available in the detail part of the report, which can be accessed by scrolling or following the links below. If you are proposing to undertake an activity that may have a significant impact on one or more matters of national environmental significance then you should consider the [Administrative Guidelines on Significance](#).

World Heritage Properties:	1
National Heritage Places:	1
Wetlands of International Importance:	None
Great Barrier Reef Marine Park:	None
Commonwealth Marine Area:	None
Listed Threatened Ecological Communities:	9
Listed Threatened Species:	46
Listed Migratory Species:	15

Other Matters Protected by the EPBC Act

This part of the report summarises other matters protected under the Act that may relate to the area you nominated. Approval may be required for a proposed activity that significantly affects the environment on Commonwealth land, when the action is outside the Commonwealth land, or the environment anywhere when the action is taken on Commonwealth land. Approval may also be required for the Commonwealth or Commonwealth agencies proposing to take an action that is likely to have a significant impact on the environment anywhere.

The EPBC Act protects the environment on Commonwealth land, the environment from the actions taken on Commonwealth land, and the environment from actions taken by Commonwealth agencies. As heritage values of a place are part of the 'environment', these aspects of the EPBC Act protect the Commonwealth Heritage values of a Commonwealth Heritage place. Information on the new heritage laws can be found at <http://www.environment.gov.au/heritage>

A [permit](#) may be required for activities in or on a Commonwealth area that may affect a member of a listed threatened species or ecological community, a member of a listed migratory species, whales and other cetaceans, or a member of a listed marine species.

Commonwealth Land:	2
Commonwealth Heritage Places:	None
Listed Marine Species:	21
Whales and Other Cetaceans:	None
Critical Habitats:	None
Commonwealth Reserves Terrestrial:	None
Commonwealth Reserves Marine:	None

Extra Information

This part of the report provides information that may also be relevant to the area you have nominated.

State and Territory Reserves:	3
Regional Forest Agreements:	None
Invasive Species:	47
Nationally Important Wetlands:	1
Key Ecological Features (Marine)	None

Stonequarry Creek Flying-fox Camp Management Plan

Details

Matters of National Environmental Significance

World Heritage Properties [\[Resource Information \]](#)

Name	State	Status
The Greater Blue Mountains Area	NSW	Declared property

National Heritage Properties [\[Resource Information \]](#)

Name	State	Status
Natural		
The Greater Blue Mountains Area	NSW	Listed place

Listed Threatened Ecological Communities [\[Resource Information \]](#)

For threatened ecological communities where the distribution is well known, maps are derived from recovery plans, State vegetation maps, remote sensing imagery and other sources. Where threatened ecological community distributions are less well known, existing vegetation maps and point location data are used to produce indicative distribution maps.

Name	Status	Type of Presence
Castlereagh Scribbly Gum and Agnes Banks Woodlands of the Sydney Basin Bioregion	Endangered	Community may occur within area
Coastal Upland Swamps in the Sydney Basin Bioregion	Endangered	Community may occur within area
Cooks River/Castlereagh Ironbark Forest of the Sydney Basin Bioregion	Critically Endangered	Community may occur within area
Cumberland Plain Shale Woodlands and Shale-Gravel Transition Forest	Critically Endangered	Community likely to occur within area
Shale Sandstone Transition Forest of the Sydney Basin Bioregion	Critically Endangered	Community likely to occur within area
Turpentine-Ironbark Forest of the Sydney Basin Bioregion	Critically Endangered	Community likely to occur within area
Upland Basalt Eucalypt Forests of the Sydney Basin Bioregion	Endangered	Community may occur within area
Western Sydney Dry Rainforest and Moist Woodland on Shale	Critically Endangered	Community likely to occur within area
White Box-Yellow Box-Blakely's Red Gum Grassy Woodland and Derived Native Grassland	Critically Endangered	Community may occur within area

Listed Threatened Species [\[Resource Information \]](#)

Name	Status	Type of Presence
Birds		
Anthochaera phrygia Regent Honeyeater [82338]	Critically Endangered	Species or species habitat known to occur within area
Botaurus poiciloptilus Australasian Bittern [1001]	Endangered	Species or species habitat known to occur within area
Calidris ferruginea Curlew Sandpiper [856]	Critically Endangered	Species or species habitat may occur within area
Dasyornis brachypterus Eastern Bristlebird [533]	Endangered	Species or species habitat may occur within area
Grantiella picta Painted Honeyeater [470]	Vulnerable	Species or species habitat likely to occur within area

Stonequarry Creek Flying-fox Camp Management Plan

Name	Status	Type of Presence
<u>Lathamus discolor</u> Swift Parrot [744]	Critically Endangered	Species or species habitat likely to occur within area
<u>Numenius madagascariensis</u> Eastern Curlew, Far Eastern Curlew [847]	Critically Endangered	Species or species habitat may occur within area
<u>Rostratula australis</u> Australian Painted Snipe [77037]	Endangered	Species or species habitat may occur within area
Fish		
<u>Macquaria australasica</u> Macquarie Perch [66632]	Endangered	Species or species habitat known to occur within area
Frogs		
<u>Heleioporus australiacus</u> Giant Burrowing Frog [1973]	Vulnerable	Species or species habitat likely to occur within area
<u>Litoria aurea</u> Green and Golden Bell Frog [1870]	Vulnerable	Species or species habitat may occur within area
<u>Litoria littlejohni</u> Littlejohn's Tree Frog, Heath Frog [64733]	Vulnerable	Species or species habitat may occur within area
Mammals		
<u>Chalinolobus dwyeri</u> Large-eared Pied Bat, Large Pied Bat [183]	Vulnerable	Species or species habitat known to occur within area
<u>Dasyurus maculatus maculatus (SE mainland population)</u> Spot-tailed Quoll, Spotted-tail Quoll, Tiger Quoll (southeastern mainland population) [75184]	Endangered	Species or species habitat known to occur within area
<u>Isodon obesulus obesulus</u> Southern Brown Bandicoot (eastern), Southern Brown Bandicoot (south-eastern) [68050]	Endangered	Species or species habitat may occur within area
<u>Petauroides volans</u> Greater Glider [254]	Vulnerable	Species or species habitat known to occur within area
<u>Petrogale penicillata</u> Brush-tailed Rock-wallaby [225]	Vulnerable	Species or species habitat known to occur within area
<u>Phascogale cinereus (combined populations of Qld, NSW and the ACT)</u> Koala (combined populations of Queensland, New South Wales and the Australian Capital Territory) [85104]	Vulnerable	Species or species habitat known to occur within area
<u>Pseudomys novaehollandiae</u> New Holland Mouse, Pookila [96]	Vulnerable	Species or species habitat likely to occur within area
<u>Pteropus poliocephalus</u> Grey-headed Flying-fox [186]	Vulnerable	Roosting known to occur within area
Plants		
<u>Acacia bynoeana</u> Bynoe's Wattle, Tiny Wattle [8575]	Vulnerable	Species or species habitat may occur within area
<u>Acacia pubescens</u> Downy Wattle, Hairy Stemmed Wattle [18800]	Vulnerable	Species or species habitat likely to occur within area

Stonequarry Creek Flying-fox Camp Management Plan

Name	Status	Type of Presence
<u>Allocaeusuarina glareicola</u> [21932]	Endangered	Species or species habitat may occur within area
<u>Asterolasia elegans</u> [56780]	Endangered	Species or species habitat may occur within area
<u>Caladenia tessellata</u> Thick-lipped Spider-orchid, Daddy Long-legs [2119]	Vulnerable	Species or species habitat likely to occur within area
<u>Commersonia prostrata</u> Dwarf Kerrawang [87152]	Endangered	Species or species habitat likely to occur within area
<u>Cryptostylis hunteriana</u> Leafless Tongue-orchid [19533]	Vulnerable	Species or species habitat may occur within area
<u>Cynanchum elegans</u> White-flowered Wax Plant [12533]	Endangered	Species or species habitat likely to occur within area
<u>Eucalyptus benthamii</u> Camden White Gum, Nepean River Gum [2821]	Vulnerable	Species or species habitat likely to occur within area
<u>Genoplesium baueri</u> Yellow Gnat-orchid [7528]	Endangered	Species or species habitat likely to occur within area
<u>Grevillea parviflora subsp. parviflora</u> Small-flower Grevillea [64910]	Vulnerable	Species or species habitat known to occur within area
<u>Haloragis exalata subsp. exalata</u> Wingless Raspwort, Square Raspwort [24636]	Vulnerable	Species or species habitat may occur within area
<u>Leucopogon exolasius</u> Woronora Beard-heath [14251]	Vulnerable	Species or species habitat likely to occur within area
<u>Melaleuca deanei</u> Deane's Melaleuca [5818]	Vulnerable	Species or species habitat likely to occur within area
<u>Pelargonium sp. Striatellum (G.W.Carr 10345)</u> Omeo Stork's-bill [84065]	Endangered	Species or species habitat likely to occur within area
<u>Persoonia acerosa</u> Needle Geebung [7232]	Vulnerable	Species or species habitat likely to occur within area
<u>Persoonia bargoensis</u> Bargo Geebung [56267]	Vulnerable	Species or species habitat likely to occur within area
<u>Persoonia glaucescens</u> Mittagong Geebung [12770]	Vulnerable	Species or species habitat likely to occur within area
<u>Persoonia hirsuta</u> Hairy Geebung, Hairy Persoonia [19006]	Endangered	Species or species habitat likely to occur within area
<u>Pimelea spicata</u> Spiked Rice-flower [20834]	Endangered	Species or species habitat likely to occur within area

Stonequarry Creek Flying-fox Camp Management Plan

Name	Status	Type of Presence
Pomaderris brunnea Rufous Pomaderris [16845]	Vulnerable	Species or species habitat likely to occur within area
Pterostylis saxicola Sydney Plains Greenhood [64537]	Endangered	Species or species habitat known to occur within area
Pultenaea glabra Smooth Bush-pea, Swamp Bush-pea [11887]	Vulnerable	Species or species habitat likely to occur within area
Thelymitra kangaloonica Kangaloon Sun Orchid [81861]	Critically Endangered	Species or species habitat likely to occur within area
Thesium australe Austral Toadflax, Toadflax [15202]	Vulnerable	Species or species habitat may occur within area
Reptiles		
Hoplocephalus bungaroides Broad-headed Snake [1182]	Vulnerable	Species or species habitat likely to occur within area
Listed Migratory Species		[Resource Information]
* Species is listed under a different scientific name on the EPBC Act - Threatened Species list.		
Name	Threatened	Type of Presence
Migratory Marine Birds		
Apus pacificus Fork-tailed Swift [678]		Species or species habitat likely to occur within area
Migratory Terrestrial Species		
Cuculus optatus Oriental Cuckoo, Horsfield's Cuckoo [86651]		Species or species habitat may occur within area
Hirundapus caudacutus White-throated Needletail [682]		Species or species habitat known to occur within area
Monarcha melanopsis Black-faced Monarch [609]		Species or species habitat known to occur within area
Motacilla flava Yellow Wagtail [644]		Species or species habitat may occur within area
Myiagra cyanoleuca Satin Flycatcher [612]		Species or species habitat known to occur within area
Rhipidura rufifrons Rufous Fantail [592]		Species or species habitat known to occur within area
Migratory Wetlands Species		
Actitis hypoleucos Common Sandpiper [59309]		Species or species habitat may occur within area
Calidris acuminata Sharp-tailed Sandpiper [874]		Species or species habitat likely to occur within area
Calidris ferruginea Curlew Sandpiper [856]	Critically Endangered	Species or species habitat may occur within area

Stonequarry Creek Flying-fox Camp Management Plan

Name	Threatened	Type of Presence
Calidris melanotos Pectoral Sandpiper [858]		Species or species habitat may occur within area
Gallinago hardwickii Latham's Snipe, Japanese Snipe [863]		Species or species habitat may occur within area
Numenius madagascariensis Eastern Curlew, Far Eastern Curlew [847]	Critically Endangered	Species or species habitat may occur within area
Pandion haliaetus Osprey [952]		Species or species habitat likely to occur within area
Tringa nebularia Common Greenshank, Greenshank [832]		Species or species habitat may occur within area

Other Matters Protected by the EPBC Act

Commonwealth Land [Resource Information]

The Commonwealth area listed below may indicate the presence of Commonwealth land in this vicinity. Due to the unreliability of the data source, all proposals should be checked as to whether it impacts on a Commonwealth area, before making a definitive decision. Contact the State or Territory government land department for further information.

Name

Commonwealth Land - Australian Telecommunications Commission
Commonwealth Land - Defence Service Homes Corporation

Listed Marine Species [Resource Information]

* Species is listed under a different scientific name on the EPBC Act - Threatened Species list.

Name	Threatened	Type of Presence
Birds		
Actitis hypoleucos Common Sandpiper [59309]		Species or species habitat may occur within area
Apus pacificus Fork-tailed Swift [678]		Species or species habitat likely to occur within area
Ardea alba Great Egret, White Egret [59541]		Breeding known to occur within area
Ardea ibis Cattle Egret [59542]		Species or species habitat may occur within area
Calidris acuminata Sharp-tailed Sandpiper [874]		Species or species habitat likely to occur within area
Calidris ferruginea Curlew Sandpiper [856]	Critically Endangered	Species or species habitat may occur within area
Calidris melanotos Pectoral Sandpiper [858]		Species or species habitat may occur within area
Cuculus saturatus Oriental Cuckoo, Himalayan Cuckoo [710]		Species or species habitat may occur within area
Gallinago hardwickii Latham's Snipe, Japanese Snipe [863]		Species or species

Stonequarry Creek Flying-fox Camp Management Plan

Name	Threatened	Type of Presence
Haliaeetus leucogaster White-bellied Sea-Eagle [943]		habitat may occur within area Species or species habitat known to occur within area
Hirundapus caudacutus White-throated Needletail [682]		Species or species habitat known to occur within area
Lathamus discolor Swift Parrot [744]	Critically Endangered	Species or species habitat likely to occur within area
Merops ornatus Rainbow Bee-eater [670]		Species or species habitat may occur within area
Monarcha melanopsis Black-faced Monarch [609]		Species or species habitat known to occur within area
Motacilla flava Yellow Wagtail [644]		Species or species habitat may occur within area
Myiagra cyanoleuca Satin Flycatcher [612]		Species or species habitat known to occur within area
Numenius madagascariensis Eastern Curlew, Far Eastern Curlew [847]	Critically Endangered	Species or species habitat may occur within area
Pandion haliaetus Osprey [952]		Species or species habitat likely to occur within area
Rhipidura rufifrons Rufous Fantail [592]		Species or species habitat known to occur within area
Rostratula benghalensis (sensu lato) Painted Snipe [889]	Endangered*	Species or species habitat may occur within area
Tringa nebularia Common Greenshank, Greenshank [832]		Species or species habitat may occur within area

Extra Information

State and Territory Reserves	[Resource Information]
Name	State
Nattai	NSW
Thirlmere Lakes	NSW
Upper Nepean	NSW

Stonequarry Creek Flying-fox Camp Management Plan

Name	Threatened	Type of Presence
Haliaeetus leucogaster White-bellied Sea-Eagle [943]		habitat may occur within area Species or species habitat known to occur within area
Hirundapus caudacutus White-throated Needletail [682]		Species or species habitat known to occur within area
Lathamus discolor Swift Parrot [744]	Critically Endangered	Species or species habitat likely to occur within area
Merops ornatus Rainbow Bee-eater [670]		Species or species habitat may occur within area
Monarcha melanopsis Black-faced Monarch [609]		Species or species habitat known to occur within area
Motacilla flava Yellow Wagtail [644]		Species or species habitat may occur within area
Myiagra cyanoleuca Satin Flycatcher [612]		Species or species habitat known to occur within area
Numenius madagascariensis Eastern Curlew, Far Eastern Curlew [847]	Critically Endangered	Species or species habitat may occur within area
Pandion haliaetus Osprey [952]		Species or species habitat likely to occur within area
Rhipidura rufifrons Rufous Fantail [592]		Species or species habitat known to occur within area
Rostratula benghalensis (sensu lato) Painted Snipe [889]	Endangered*	Species or species habitat may occur within area
Tringa nebularia Common Greenshank, Greenshank [832]		Species or species habitat may occur within area

Extra Information

State and Territory Reserves	[Resource Information]
Name	State
Nattai	NSW
Thirlmere Lakes	NSW
Upper Nepean	NSW

Stonequarry Creek Flying-fox Camp Management Plan

Invasive Species [Resource Information]

Weeds reported here are the 20 species of national significance (WoNS), along with other introduced plants that are considered by the States and Territories to pose a particularly significant threat to biodiversity. The following feral animals are reported: Goat, Red Fox, Cat, Rabbit, Pig, Water Buffalo and Cane Toad. Maps from Landscape Health Project, National Land and Water Resources Audit, 2001.

Name	Status	Type of Presence
Birds		
<i>Acridotheres tristis</i> Common Myna, Indian Myna [387]		Species or species habitat likely to occur within area
<i>Alauda arvensis</i> Skylark [656]		Species or species habitat likely to occur within area
<i>Anas platyrhynchos</i> Mallard [974]		Species or species habitat likely to occur within area
<i>Carduelis carduelis</i> European Goldfinch [403]		Species or species habitat likely to occur within area
<i>Columba livia</i> Rock Pigeon, Rock Dove, Domestic Pigeon [803]		Species or species habitat likely to occur within area
<i>Lonchura punctulata</i> Nutmeg Mannikin [399]		Species or species habitat likely to occur within area
<i>Passer domesticus</i> House Sparrow [405]		Species or species habitat likely to occur within area
<i>Pycnonotus jocosus</i> Red-whiskered Bulbul [631]		Species or species habitat likely to occur within area
<i>Streptopelia chinensis</i> Spotted Turtle-Dove [780]		Species or species habitat likely to occur within area
<i>Stumus vulgaris</i> Common Starling [389]		Species or species habitat likely to occur within area
<i>Turdus merula</i> Common Blackbird, Eurasian Blackbird [596]		Species or species habitat likely to occur within area
Mammals		
<i>Bos taurus</i> Domestic Cattle [16]		Species or species habitat likely to occur within area
<i>Canis lupus familiaris</i> Domestic Dog [82654]		Species or species habitat likely to occur within area
<i>Felis catus</i> Cat, House Cat, Domestic Cat [19]		Species or species habitat likely to occur within area
Feral deer Feral deer species in Australia [85733]		Species or species habitat likely to occur within area
<i>Lepus capensis</i> Brown Hare [127]		Species or species habitat likely to occur within area

Stonequarry Creek Flying-fox Camp Management Plan

Name	Status	Type of Presence
Mus musculus House Mouse [120]		Species or species habitat likely to occur within area
Oryctolagus cuniculus Rabbit, European Rabbit [128]		Species or species habitat likely to occur within area
Rattus norvegicus Brown Rat, Norway Rat [83]		Species or species habitat likely to occur within area
Rattus rattus Black Rat, Ship Rat [84]		Species or species habitat likely to occur within area
Vulpes vulpes Red Fox, Fox [18]		Species or species habitat likely to occur within area
Plants		
Alternanthera philoxeroides Alligator Weed [11620]		Species or species habitat likely to occur within area
Anredera cordifolia Madeira Vine, Jalap, Lamb's-tail, Mignonette Vine, Anredera, Gulf Madeiravine, Heartleaf Madeiravine, Potato Vine [2643]		Species or species habitat likely to occur within area
Asparagus aethiopicus Asparagus Fern, Ground Asparagus, Basket Fern, Sprengi's Fern, Bushy Asparagus, Emerald Asparagus [62425]		Species or species habitat likely to occur within area
Asparagus asparagoides Bridal Creeper, Bridal Veil Creeper, Smilax, Florist's Smilax, Smilax Asparagus [22473]		Species or species habitat likely to occur within area
Asparagus scandens Asparagus Fern, Climbing Asparagus Fern [23255]		Species or species habitat likely to occur within area
Cabomba caroliniana Cabomba, Fanwort, Carolina Watershield, Fish Grass, Washington Grass, Watershield, Carolina Fanwort, Common Cabomba [5171]		Species or species habitat likely to occur within area
Chrysanthemoides monilifera Bitou Bush, Boneseed [18983]		Species or species habitat may occur within area
Chrysanthemoides monilifera subsp. monilifera Boneseed [16905]		Species or species habitat likely to occur within area
Chrysanthemoides monilifera subsp. rotundata Bitou Bush [16332]		Species or species habitat likely to occur within area
Cytisus scoparius Broom, English Broom, Scotch Broom, Common Broom, Scottish Broom, Spanish Broom [5934]		Species or species habitat likely to occur within area
Eichhornia crassipes Water Hyacinth, Water Orchid, Nile Lily [13466]		Species or species habitat likely to occur within area
Genista monspessulana Montpellier Broom, Cape Broom, Canary Broom, Common Broom, French Broom, Soft Broom [20126]		Species or species habitat likely to occur within area
Genista sp. X Genista monspessulana Broom [67538]		Species or species habitat may occur within area

Stonequarry Creek Flying-fox Camp Management Plan

Name	Status	Type of Presence
Lantana camara Lantana, Common Lantana, Kamara Lantana, Large-leaf Lantana, Pink Flowered Lantana, Red Flowered Lantana, Red-Flowered Sage, White Sage, Wild Sage [10892]		Species or species habitat likely to occur within area
Lycium ferocissimum African Boxthorn, Boxthorn [19235]		Species or species habitat likely to occur within area
Nassella neesiana Chilean Needle grass [67699]		Species or species habitat likely to occur within area
Nassella trichotoma Serrated Tussock, Yass River Tussock, Yass Tussock, Nassella Tussock (NZ) [18884]		Species or species habitat likely to occur within area
Opuntia spp. Prickly Pears [82753]		Species or species habitat likely to occur within area
Pinus radiata Radiata Pine Monterey Pine, Insignis Pine, Wilding Pine [20780]		Species or species habitat may occur within area
Protasparagus densiflorus Asparagus Fern, Plume Asparagus [5015]		Species or species habitat likely to occur within area
Rubus fruticosus aggregate Blackberry, European Blackberry [68406]		Species or species habitat likely to occur within area
Sagittaria platyphylla Delta Arrowhead, Arrowhead, Slender Arrowhead [68483]		Species or species habitat likely to occur within area
Salix spp. except S.babylonica, S.x calodendron & S.x reichardtii Willows except Weeping Willow, Pussy Willow and Sterile Pussy Willow [68497]		Species or species habitat likely to occur within area
Salvinia molesta Salvinia, Giant Salvinia, Aquarium Watermoss, Kariba Weed [13665]		Species or species habitat likely to occur within area
Senecio madagascariensis Fireweed, Madagascar Ragwort, Madagascar Groundsel [2624]		Species or species habitat likely to occur within area
Ulex europaeus Gorse, Furze [7693]		Species or species habitat likely to occur within area

Nationally Important Wetlands		[Resource Information]
Name	State	
Thirlmere Lakes	NSW	

Stonequarry Creek Flying-fox Camp Management Plan

Caveat

The information presented in this report has been provided by a range of data sources as acknowledged at the end of the report.

This report is designed to assist in identifying the locations of places which may be relevant in determining obligations under the Environment Protection and Biodiversity Conservation Act 1999. It holds mapped locations of World and National Heritage properties, Wetlands of International and National Importance, Commonwealth and State/Territory reserves, listed threatened, migratory and marine species and listed threatened ecological communities. Mapping of Commonwealth land is not complete at this stage. Maps have been collated from a range of sources at various resolutions.

Not all species listed under the EPBC Act have been mapped (see below) and therefore a report is a general guide only. Where available data supports mapping, the type of presence that can be determined from the data is indicated in general terms. People using this information in making a referral may need to consider the qualifications below and may need to seek and consider other information sources.

For threatened ecological communities where the distribution is well known, maps are derived from recovery plans, State vegetation maps, remote sensing imagery and other sources. Where threatened ecological community distributions are less well known, existing vegetation maps and point location data are used to produce indicative distribution maps.

Threatened, migratory and marine species distributions have been derived through a variety of methods. Where distributions are well known and if time permits, maps are derived using either thematic spatial data (i.e. vegetation, soils, geology, elevation, aspect, terrain, etc) together with point locations and described habitat; or environmental modelling (MAXENT or BIOCLIM habitat modelling) using point locations and environmental data layers.

Where very little information is available for species or large number of maps are required in a short time-frame, maps are derived either from 0.04 or 0.02 decimal degree cells; by an automated process using polygon capture techniques (static two kilometre grid cells, alpha-hull and convex hull); or captured manually or by using topographic features (national park boundaries, islands, etc). In the early stages of the distribution mapping process (1999-early 2000s) distributions were defined by degree blocks, 100K or 250K map sheets to rapidly create distribution maps. More reliable distribution mapping methods are used to update these distributions as time permits.

Only selected species covered by the following provisions of the EPBC Act have been mapped:

- migratory and
- marine

The following species and ecological communities have not been mapped and do not appear in reports produced from this database:

- threatened species listed as extinct or considered as vagrants
- some species and ecological communities that have only recently been listed
- some terrestrial species that overfly the Commonwealth marine area
- migratory species that are very widespread, vagrant, or only occur in small numbers

The following groups have been mapped, but may not cover the complete distribution of the species:

- non-threatened seabirds which have only been mapped for recorded breeding sites
- seals which have only been mapped for breeding sites near the Australian continent

Such breeding sites may be important for the protection of the Commonwealth Marine environment.

Coordinates

-34.18 150.61057

Acknowledgements

This database has been compiled from a range of data sources. The department acknowledges the following custodians who have contributed valuable data and advice:

- [Office of Environment and Heritage, New South Wales](#)
- [Department of Environment and Primary Industries, Victoria](#)
- [Department of Primary Industries, Parks, Water and Environment, Tasmania](#)
- [Department of Environment, Water and Natural Resources, South Australia](#)
- [Department of Land and Resource Management, Northern Territory](#)
- [Department of Environmental and Heritage Protection, Queensland](#)
- [Department of Parks and Wildlife, Western Australia](#)
- [Environment and Planning Directorate, ACT](#)
- [Birdlife Australia](#)
- [Australian Bird and Bat Banding Scheme](#)
- [Australian National Wildlife Collection](#)
- Natural history museums of Australia
- [Museum Victoria](#)
- [Australian Museum](#)
- [South Australian Museum](#)
- [Queensland Museum](#)
- [Online Zoological Collections of Australian Museums](#)
- [Queensland Herbarium](#)
- [National Herbarium of NSW](#)
- [Royal Botanic Gardens and National Herbarium of Victoria](#)
- [Tasmanian Herbarium](#)
- [State Herbarium of South Australia](#)
- [Northern Territory Herbarium](#)
- [Western Australian Herbarium](#)
- [Australian National Herbarium, Canberra](#)
- [University of New England](#)
- [Ocean Biogeographic Information System](#)
- [Australian Government, Department of Defence Forestry Corporation, NSW](#)
- [Geoscience Australia](#)
- [CSIRO](#)
- [Australian Tropical Herbarium, Cairns](#)
- [eBird Australia](#)
- [Australian Government – Australian Antarctic Data Centre](#)
- [Museum and Art Gallery of the Northern Territory](#)
- [Australian Government National Environmental Science Program](#)
- [Australian Institute of Marine Science](#)
- [Reef Life Survey Australia](#)
- [American Museum of Natural History](#)
- [Queen Victoria Museum and Art Gallery, Inveresk, Tasmania](#)
- [Tasmanian Museum and Art Gallery, Hobart, Tasmania](#)
- Other groups and individuals

The Department is extremely grateful to the many organisations and individuals who provided expert advice and information on numerous draft distributions.

Please feel free to provide feedback via the [Contact Us](#) page.

© Commonwealth of Australia
Department of the Environment
GPO Box 787
Canberra ACT 2601 Australia
+61 2 6274 1111

Appendix 5: Additional human and animal health information

Australian bat lyssavirus

ABLV is a rabies-like virus that may be found in all flying-fox species on mainland Australia. It has also been found in an insectivorous microbat and it is assumed it may be carried by any bat species. The probability of human infection with ABLV is very low with less than 1% of the flying-fox population being affected (DPI 2013) and transmission requiring direct contact with an infected animal that is secreting the virus. In Australia three people have died from ABLV infection since the virus was identified in 1996 (NSW Health 2013).

Domestic animals are also at risk if exposed to ABLV. In 2013, ABLV infections were identified in two horses (Shinwari et al. 2014). There have been no confirmed cases of ABLV in dogs in Australia; however, transmission is possible (McCall et al. 2005) and consultation with a veterinarian should be sought if exposure is suspected.

Transmission of the virus from bats to humans is through a bite or scratch, but may have potential to be transferred if bat saliva directly contacts the eyes, nose, mouth or broken skin. ABLV is unlikely to survive in the environment for more than a few hours, especially in dry environments that are exposed to sunlight (NSW Health 2013).

Transmission of closely related viruses suggests that contact or exposure to bat faeces, urine or blood does not pose a risk of exposure to ABLV, nor does living, playing or walking near bat roosting areas (NSW Health 2013).

The incubation period in humans is assumed similar to rabies and variable between two weeks and several years. Similarly the disease in humans presents essentially the same clinical picture as classical rabies. Once clinical signs have developed the infection is invariably fatal. However, infection can easily be prevented by avoiding direct contact with bats (i.e. handling). Pre-exposure vaccination provides reliable protection from the disease for people who are likely to have direct contact with bats, and it is generally a mandatory workplace health and safety requirement that all persons working with bats receive pre-vaccination and have their level of protection regularly assessed. Like classical rabies, ABLV infection in humans also appears to be effectively treated using post-exposure vaccination and so any person who suspects they have been exposed should seek immediate medical treatment. Post-exposure vaccination is usually ineffective once clinical manifestations of the disease have commenced.

If a person is bitten or scratched by a bat they should:

- wash the wound with soap and water for at least five minutes (**do not scrub**)
- contact their doctor immediately to arrange for post-exposure vaccinations.

If bat saliva contacts the eyes, nose, mouth or an open wound, flush thoroughly with water and seek immediate medical advice.

Hendra virus

Flying-foxes are the natural host for Hendra virus (HeV), which can be transmitted from flying-foxes to horses. Infected horses sometimes amplify the virus and can then transmit it to other horses, humans and on two occasions, dogs (DPI 2014). There is no evidence that the virus can be passed directly from flying-foxes to humans or to dogs (AVA 2015). Clinical studies have shown cats, pigs, ferrets and guinea pigs can carry the infection (DPI 2015a).

Although the virus is periodically present in flying-fox populations across Australia, the likelihood of horses becoming infected is low and consequently human infection is extremely

rare. Horses are thought to contract the disease after ingesting forage or water contaminated primarily with flying-fox urine (CDC 2014).

Humans may contract the disease after close contact with an infected horse. HeV infection in humans presents as a serious and often fatal respiratory and/or neurological disease and there is currently no effective post-exposure treatment or vaccine available for people. The mortality rate in horses is greater than 70% (DPI 2014). Since 1994, 81 horses have died and four of the seven people infected with HeV have lost their lives (DPI 2014).

Previous studies have shown that HeV spillover events have been associated with foraging flying-foxes rather than camp locations. Therefore risk is considered similar at any location within the range of flying-fox species and all horse owners should be vigilant. Vaccination of horses can protect horses and subsequently humans from infection (DPI 2014), as can appropriate horse husbandry (e.g. covering food and water troughs, fencing flying-fox foraging trees in paddocks, etc.).

Although all human cases of HeV to date have been contracted from infected horses and direct transmission from bats to humans has not yet been reported, particular care should be taken by select occupational groups that could be uniquely exposed. For example, persons who may be exposed to high levels of HeV via aerosol of heavily contaminated substrate should consider additional PPE (e.g. respiratory filters), and potentially dampening down dry dusty substrate.

Menangle virus

Menangle virus (also known as bat paramyxovirus no. 2) was first isolated from stillborn piglets from a NSW piggery in 1997. Little is known about the epidemiology of this virus, except that it has been recorded in flying-foxes, pigs and humans (AVA 2015). The virus caused reproductive failure in pigs and severe febrile (flu-like) illness in two piggery workers employed at the same Menangle piggery where the virus was recorded (AVA 2015). The virus is thought to have been transmitted to the pigs from flying-foxes via an oral-faecal matter route (AVA 2015). Flying-foxes had been recorded flying over the pig yards prior to the occurrence of disease symptoms. The two infected piggery workers made a full recovery and this has been the only case of Menangle virus recorded in Australia.

General health considerations

Flying-foxes, like all animals, carry bacteria and other microorganisms in their guts, some of which are potentially pathogenic to other species. Direct contact with faecal material should be avoided and general hygiene measures taken to reduce the low risk of gastrointestinal and other disease.

Contamination of water supplies by any animal excreta (birds, amphibians and mammals such as flying-foxes) poses a health risk to humans. Household tanks should be designed to minimise potential contamination, such as using first flush diverters to divert contaminants before they enter water tanks. Trimming vegetation overhanging the catchment area (e.g. the roof of a house) will also reduce wildlife activity and associated potential contamination. Tanks should also be appropriately maintained and flushed, and catchment areas regularly cleaned to remove potential contaminants.

Public water supplies are regularly monitored for harmful microorganisms, and are filtered and disinfected before being distributed. Management plans for community supplies should consider whether any large congregation of animals, including flying-foxes, occurs near the supply or catchment area. Where they do occur, increased frequency of monitoring should be considered to ensure early detection and management of contaminants.

Appendix 6: Expert assessment requirements

The Plan template identifies where expert input is required. The following are the minimum required skills and experience which must be demonstrated by each expert.

Flying-fox expert

Essential

- Knowledge of flying-fox habitat requirements.
- Knowledge and experience in flying-fox camp management.
- Knowledge of flying-fox behaviour, including ability to identify signs of flying-fox stress.
- Ability to differentiate between breeding and non-breeding females.
- Ability to identify females in final trimester.
- Ability to estimate age of juveniles.
- Experienced in flying-fox population monitoring including static and fly-out counts, demographics and visual health assessments.

Desirable

- It is strongly recommended that the expert is independent of the Plan owner to ensure transparency and objectivity. OEH may be able to provide assistance with flying-fox experts.
- ABLV-vaccinated (N.B. This is often an essential requirement during management implementation as detailed within the template).
- Trained in flying-fox rescue (N.B. This is often an essential requirement during management implementation as detailed within the template).
- Local knowledge and experience.

Ecologist

Essential

- At least five years demonstrated experience in ecological surveys, including identifying fauna and flora to species level, fauna habitat and ecological communities.
- The ability to identify flora and fauna, including ground-truthing of vegetation mapping.
- Formal training in ecology or similar, specifically flora and fauna identification.

Desirable

- Tertiary qualification in ecology or similar.
- Local knowledge and experience.
- Accredited Biobanking Assessor under the *Threatened Species Conservation Act 1995*.
- Practising member of the Ecological Consultants Association of NSW.

Depending on the site, for example when vegetation management is proposed for an endangered ecological community or an area with a high likelihood of containing other threatened flora and fauna species, a specialist in that field (e.g. specialist botanist) may be required.

Appendix 7: Dispersal results summary

Roberts and Eby (2013) summarised 17 known flying-fox dispersals between 1990 and 2013, and made the following conclusions:

1. In all cases, dispersed animals did not abandon the local area⁶.
2. In 16 of the 17 cases, dispersals did not reduce the number of flying-foxes in the local area.
3. Dispersed animals did not move far (in approx. 63% of cases the animals only moved <600 m from the original site, contingent on the distribution of available vegetation). In 85% of cases, new camps were established nearby.
4. In all cases, it was not possible to predict where replacement camps would form.
5. Conflict was often not resolved. In 71% of cases conflict was still being reported either at the original site or within the local area years after the initial dispersal actions.
6. Repeat dispersal actions were generally required (all cases except where extensive vegetation removal occurred).
7. The financial costs of all dispersal attempts were high, ranging from tens of thousands of dollars for vegetation removal to hundreds of thousands for active dispersals (e.g. using noise, smoke, etc.).

Ecosure, in collaboration with a Griffith University Industry Affiliates Program student, researched outcomes of management in Queensland between November 2013 and November 2014 (the first year since the current Queensland state flying-fox management framework was adopted on 29 November 2013). An overview of findings⁷ is summarised below.

- There were attempts to disperse 25 separate roosts in Queensland (compared with nine roosts between 1990 and June 2013 analysed in Roberts and Eby (2013)). Compared with the historical average (less than 0.4 roosts/year) the number of roosts dispersed in the year since the Code was introduced has increased by 6250%.
- Dispersal methods included fog⁸, birdfrite, lights, noise, physical deterrents, smoke, extensive vegetation modification, water (including cannons), paintball guns and helicopters.
- The most common dispersal methods were extensive vegetation modification alone and extensive vegetation modification combined with other methods.
- In nine of the 24 roosts dispersed, dispersal actions did not reduce the number of flying-foxes in the LGA.
- In all cases it was not possible to predict where new roosts would form.
- When flying-foxes were dispersed, they did not move further than 6 km away.
- As at November 2014 repeat actions had already been required in 18 cases.
- Conflict for the council and community was resolved in 60% of cases, but with many councils stating that they feel this resolution is only temporary.
- The financial costs of all dispersal attempts, regardless of methods used were considerable, ranging from \$7500 to more than \$400,000 (with costs ongoing).

⁶ Local area is defined as the area within a 20 km radius of the original site = typical feeding area of a flying-fox.

⁷ This was based on responses to questionnaires sent to councils; some did not respond and some omitted responses to some questions.

⁸ Fog refers to artificial smoke or vapours generated by smoke/fog machines. Many chemical substances used to generate smoke/fog in these machines are considered toxic.

Appendix 8: Odour neutralising information.

About Ecolo AirSolution®

What is Ecolo airSolution®?

AirSolution® is a proprietary mixture of essential oils and odiferous organic compounds extracted from different parts of plants: flowers, leaves, stems, peel etc. Each Ecolo formulation may contain up to one hundred different ingredients.

Why so many ingredients?

Odorous emissions and odorous ambient air are complex mixtures of different compounds and require a complex mixture of ingredients to ensure proper treatment. E.g. Odorous emissions from a wastewater plant may contain up to 25 principal odorants. Each airSolution® is carefully formulated to provide optimum performance in the application it is designed for. Ecolo has more than 60 current airSolution® patents for a huge range of applications with more pending.

How Ecolo airSolution® works

When decomposition in one form or another is occurring, the components involved (usually some combination of oxygen, hydrogen, carbon, nitrogen and sulfur) are going through a series of reactions until the decomposition cycle is complete. Upon completion, stable products such as carbon dioxide, water, nitrogen (in the form of nitrates) and sulfur are formed. However, many of the forms and compounds which occur along the way are odorous and noxious. Most odorous gases are composed of various combinations and permutations of the elements listed above - hydrogen, sulfur, oxygen, nitrogen and carbon. Certainly there are other odorous compounds and elements (chlorine as an example), but most organic odours are by their very nature and definition, composed of the above elements.

Ecolo airSolution® works to enable these compounds to continue degrading towards their stable, non-odorous destinations. By freeing the components of an odorous molecule to combine and recombine with other component. Ecolo airSolution® works almost instantaneously.

In the simplest terms, airSolution® enables trapped oxygen, carbon and hydrogen to reform as water and carbon dioxide and volatile nitrous compounds and sulfides to stabilize as nitrates and sulfur. This is not a masking of the offending molecules. This is transformation. The resulting decrease in odorous gas levels is quantifiable and measurable, and works on hydrocarbons,

aldehydes, mercaptans, amines, sulfides, ammonia, ketones and various other organic compounds.

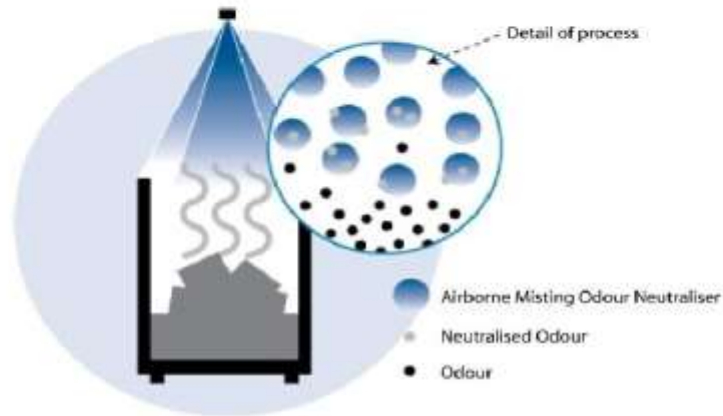

Deodorizing with Ecolo airSolution®

The mechanism of odor elimination with Ecolo airSolution® combines the process of absorption and the process of neutralization through series of chemical reactions.

Diluted airSolution® is introduced into the treated air or onto the treated surface in the form of very fine droplets to absorb the odorous gases into the liquid phase.

Once the odorous molecules are absorbed into or onto individual droplets of airSolution®, the chemical being used within the droplets can proceed to react with the odorous compound, destroying it.

Each Ecolo airSolution® is a complex mixture of essential oils. Chemical examination of these essential oils shows that they consist of various organic compounds mostly aldehydes, ketones, esters, and alcohols that are highly reactive due to specific functional groups.

The characteristic functional group of aldehydes and ketones is **the carbonyl group**:

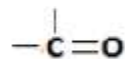

Due to this carbonyl group aldehydes and ketones have the capacity to react with nitrogen and sulfur bearing compounds, which are the principal sources of disagreeable odors in many applications. Some types of aldehydes may also react with unpleasant smelling aldehydes, which are also at the origin of bad odors.

Alcohols are also highly reactive compounds which contain **the hydroxyl group:**

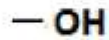

Due to this group alcohols react with odor causing aldehydes and fatty acids.

Esters are very important constituents of essential oils, they react with either ammonia or amines due to their specific functional group:

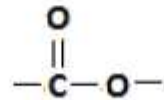

Some esters incorporated in airSolution® contain double bonds that make these compounds even more reactive, and such esters are known for their ability of abating malodors.

When odorous molecules react with the molecules of airSolution®, new molecules are formed that are larger in size, less volatile, and consequently less odorous or not odorous at all.

Ecolo Odour Control Technologies is backed by more than 30 years of experience with a dedicated lab and in-house expertise in odour evaluation and solutions.



AMS SYSTEM

ODOR COUNTERACTANT DELIVERY EQUIPMENT

- Integrated Controller Design
- Adjustable Touch-Pad Programming
- Weather Resistant Enclosure
- Internal Pressure Control
- Remote Control Ready



The Ecolo AMS System, combined with our effective odor specific AirSolutions is the most effective method for eliminating odors in a broad range of industrial and environmental applications.



AMS System - Odor counteractant delivery system

A sophisticated automated misting system with features and versatility like no other competitively priced system in the industry. AirStreme AMS series Control Units integrate advanced electronics and durable mid-pressure pumps into one sleek and refined misting system. The AMS has the flexibility of digital programming with a back lit display and a 365-day calendar clock to accommodate even the most demanding range of programming options.

Whether used for misting water or chemical formulations, AirStreme AMS Control Units provide high quality and reliable service for many industrial and consumer applications. AMS Control Units set the standard for class, function and versatility.

- Trash Rooms
- Composting Plants
- Small Industrial Projects
- Processing Plants
- Transfer Stations
- Wastewater
- Exhaust Stacks
- Other Odorous Applications

Controller Specifications:

Depth 18.54 cm/7.3"
 Width 34.29 cm/13.5"
 Height 37.03 cm/14.58"
 Weight 13.15 kg/29 lbs

VOLTS	HZ	AMPS	HP	MAX AMB TEMP	NOZZLES
110/220	60	6.5	1/3	40°C (110°F)	≤ 80

The system is based on spray events. There can be up to 10 spray events in auto mode and up to 10 independent spray events in repeat mode. In auto mode the spray time is specified by the start time and the duration of spray. During the spray time the spray is continuous. In repeat mode the spray time is specified by the start time and stop time. In addition the spray pattern during the spray time is specified by the on cycle time and off cycle time.

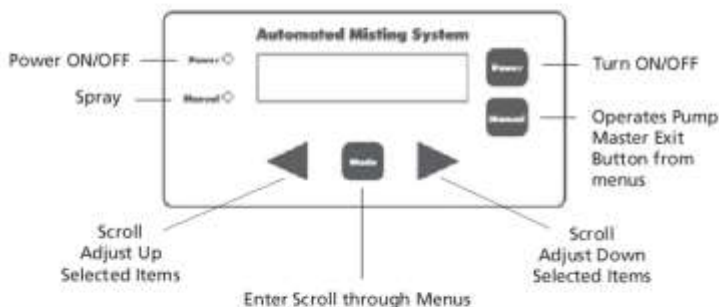

Standard Install Configuration

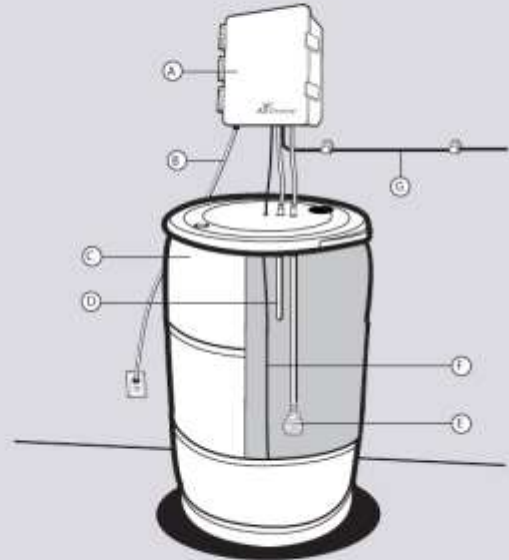

PART	DESCRIPTION
A	AMS Controller
B	Power Cord
C	55 Gallon Drum
D	Return Line
E	Strainer
F	Tank Level Sensor
G	Discharge Line

FEATURES AND BENEFITS

- Integrated Controller Design
- Adjustable Touch-Pad Programming
- Weather Resistant Enclosure
- Internal Pressure Control
- Remote Control Ready
- 365-day Calendar Clock
- Large Backlit LCD display
- Non-Volatile Memory
- Battery Back-up
- Multiple Inputs
- Tamper Proof
- Easy to Install
- Electrically Certified

Ecolo Odor Control Technologies

59 Penn Drive, Toronto, ON,
 Canada, M9L 2A6
 (800) NO SMELL | (416) 740.3900
 info@ecolo.com | www.ecolo.com



REV042811